

DANAÏS TBT II – Cryogenic Offset Disc Butterfly Valve

Industry

Water

Waste Water

Energy

Building Services

Mining



Applications:

- All liquefied gases
- LNG tankers
- LNG terminals
- Oxygen
- Process engineering
- Pipelines and tank farms

More information:

www.ksb.com/products

DanaïS TBT II
Butt Weld Side Entry
with hydraulic
actuator

DANAÏS TBT II – Cryogenic Offset Disc Butterfly Valve

1 Straightforward insulation

of the actuator for cryogenics applications through long neck extension.

2 Perfect tightness

- Plain bearings ensure a perfect guiding of the shaft and highest up-/down-stream tightness performances even at full rating.
- Two independent sealing devices.
No need to retighten the packing gland.

3 Easy maintenance

- Removable cover for periodic checking of seat and disc. Replacement without specific tool.

4 Long life – low life cycle cost

- Seal ring, located in the body, is not subjected to wear.
- Over-travel stop protects seat and disc in case of wrong (re)assembly of the actuator.

5 KSB design metal gasket ensures:

- Unmatched tightness even in reverse flow direction and at cryogenic temperature.
- Long service life.
- Easy maintenance.

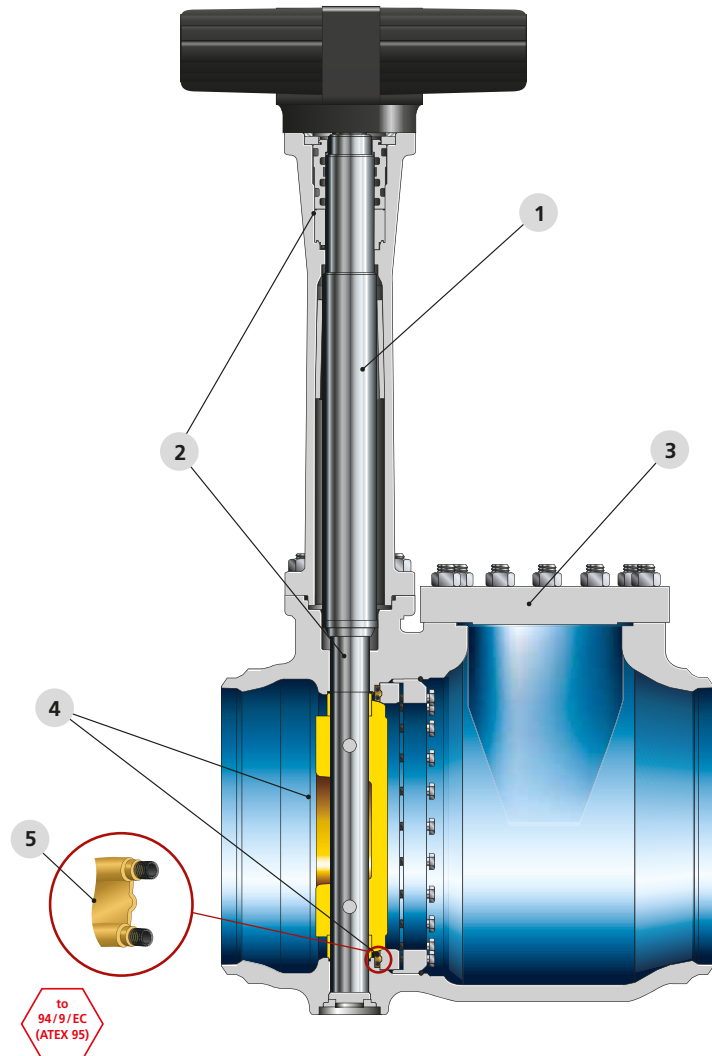

Materials

Body	Stainless steel CF 8 M / 1.4408 Stainless steel CF 3 M / 1.4409
Stem	Stainless steel A479 gr.316L Stainless steel A479 gr.XM19
Disc	Stainless steel CF 8 M / 1.4408 with stellite overlay
Seat	Copper

Note

ATEX design in compliance with the 94/9/EC Directive.
Fire-safe design to BS 6755 – API 6FA.
Flanged ends to EN, ASME.
Other flanges on request.
Safety requirements in compliance with the 97/23/EC European Pressure Equipment Directive.
Lip seal ring for installation in any position.
Drip plate for insulation.

Technical data

Size	DN 50 to 1200
Pressure class	150, 300
Temperature range	-250 °C to + 200 °C
Body design	Full lug body, flanged body, butt weld side entry
Face to face	ISO 5752 serie 13 / 20 ISO 558.1 serie 13 / 20 API 609 class 150 / 300
Actuators	ACTO / ENNACTO ACTAIR / DYNACTAIR MR
Automation	AMTROBOX R



KSB Aktiengesellschaft
Johann-Klein-Straße 9
67227 Frankenthal (Germany)
www.ksb.com