

ECOLINE 150-600 – Globe and Gate Valve with Gland Packing



ECOLINE GTC

Applications:

- Refineries, power stations, process engineering and general industry
- For water, steam, gas, oil, and other media
- Other applications on request

The limits given in the technical data must be complied with. Please contact us for details.

More information:

www.ksb.com/products



ECOLINE GLC



ECOLINE SCC

ECOLINE 150-600 – Globe and Gate Valve with Gland Packing

- 1 Long gland life and high functional reliability**
 - Stem with burnished shank (0.2 µm)
 - Graphite gland packing with packing end rings
 - Two-piece self aligning gland
- 2 Reliable sealing and longer service life**
 - Hard-faced valve seat and flexible wedge made of wear and corrosion resistant materials
 - Male/female joint prevents over-tightening of the fully confined gasket
- 3 Additional safety and blow-out protection**
 - Hardened backseat as standard
- 4 Versatile application**
 - Ni steel stem nut
- 5 Extended maintenance-free operating life time***
 - High wear travel allowance
- 6 Space-saving design***
 - Non-rising hand wheel

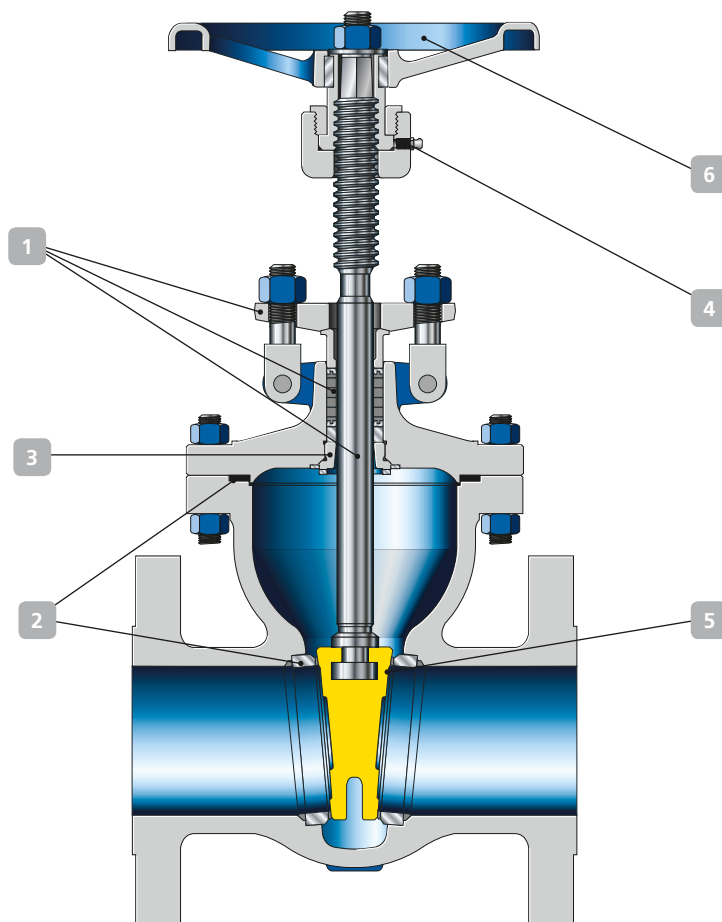

*only for gate valve

Temperature		Class 150		Class 300		Class 600	
°F	°C	psi	bar	psi	bar	psi	bar
32 to 100	0 to 38	285	19.7	740	51.0	1480	102.0
200	93	260	17.9	680	46.9	1360	93.8
300	149	230	15.9	655	45.2	1310	90.3
400	204	200	13.8	635	43.8	1265	87.2
500	260	170	11.7	605	41.7	1205	83.1
600	316	140	9.7	570	39.3	1135	78.3
650	343	125	8.6	550	37.9	1100	75.8
700	371	110	7.6	530	36.5	1060	73.1
750	399	95	6.6	505	34.8	1015	70.0
800	427	80	5.5	410	28.3	825	56.9
850	454	65	4.5	320	22.1	640	44.1
900	482	50	3.4	230	15.9	460	31.7
950	510	35	2.4	135	9.3	275	19.0
1000	538	20	1.4	85	5.9	170	11.7

Technical data

Size	2" ~ 36"
Pressure	Class 150~600
Pressure	Up to 100 bar
Temperature	Up to 816 °C

Materials

WCB, LCB, WC6, WC9, CF8, CF8M etc.

Trim 1, 2, 5, 8, 10, 12, 16 etc.

Additional type series

ECOLINE GLC globe valve

ECOLINE SCC swing check valve

Variants on request

▪ With gears	▪ Radiography test
▪ Electric actuators	▪ Butt weld ends as per ASME B16.25
▪ Bypass design	▪ Other variants



KSB Aktiengesellschaft
Johann-Klein-Straße 9
67227 Frankenthal (Germany)
www.ksb.com