

Non-return Valve

BOA-R

PN 6/16
DN 15-350
Flanged ends

Type Series Booklet



Legal information/Copyright

Type Series Booklet BOA-R

KSB Aktiengesellschaft Pegnitz

All rights reserved. Contents provided herein must neither be distributed, copied, reproduced, edited or processed for any other purpose, nor otherwise transmitted, published or made available to a third party without KSB's express written consent.

Subject to technical modification without prior notice.

© KSB Aktiengesellschaft Frankenthal 2012

Check Valves and Strainers

Non-return Valves

BOA-R



Main applications

- Hot-water heating systems
- Boiler feed applications
- Chemical industry
- Process engineering
- Heat recovery systems
- Sugar industry

Fluids handled

- High-temperature hot water
- Saturated steam
- Thermal oil
- Liquids not chemically or mechanically aggressive to the valve materials.
- Other fluids on request.

Operating data

Operating properties

Characteristic	Value	
	JL 1040	JS 1025
Nominal pressure	PN 6/16	PN 16
Nominal size	DN 15-300	DN 15-350
Max. permissible pressure	16 bar	16 bar
Max. permissible temperature	300 °C	350 °C

Selection as per pressure/temperature ratings (⇒ Page 4)

Design details

Design

- Straight-way or angle pattern with horizontal seat
- Spring-loaded check disc
- Flanges to DIN EN 1092-2 Type 21
- Exterior coating: blue RAL 5002
- The valves satisfy the safety requirements of Annex I of the European Pressure Equipment Directive 97/23/EC (PED) for fluids in Groups 1 and 2.
- The valves do not have a potential internal source of ignition and can be used in potentially explosive atmospheres, Group II, category 2 (zones 1+21) and category 3 (zones 2+22) to ATEX 94/9/EC.
- Type-tested to the specifications of Germanischer Lloyd

Variants

- Oil and grease-free: lubricated exclusively by mineral oil free lubricants approved by the German Federal Office for Materials Testing (Bundesanstalt für Materialforschung und -prüfung, BAM)
- Other flange designs
- High-temperature resistant paint (grey aluminium)
- Low-temperature steel bolts for temperatures down to -30 °C (JS 1025 only) up to 0.75 x PN (max.)
- Certification to customer specification

Body materials

Overview of materials available for straight-way valve

Material	Material number	Temperature limit
EN-GJL-250	JL 1040	up to 300 °C
EN-GJS-400-18-LT	JS 1025	up to 350 °C

Overview of materials available for angle valve

Material	Material number	Temperature limit
EN-GJL-250	JL 1040	up to 300 °C

Product benefits

- High functional reliability and corrosion resistance owing to check disc and closing springs made of stainless steel.
- Cover removable for inspection.
- Variable use. Can be installed in vertical pipes with or without spring.

Related documents

- Operating manual 0570.8

On all enquiries/orders please specify

1. Type
2. Nominal pressure
3. Nominal size
4. Material
5. Variants
6. Number of type series booklet

Pressure/temperature ratings

Test and operating pressures

Nominal pressure	Material	Body pressure test	Seat tightness test	Permissible operating pressures in bar at temperatures in °C ¹⁾²⁾							
				with water							
				P10, P11 ³⁾		P12 ⁴⁾					
PN		[bar]	[bar]	-10 to +120	150	180	200	230	250	300	350
6	EN-GJL-250	9	6,6	6	5,4	5	4,8	4,4	4,2	3,6	-
16	EN-GJL-250	24	17,6	16	14,4	13,4	12,8	11,8	11,2	9,6	-
16	EN-GJS-400-18-LT	24	17,6	16	15,5		14,7		13,9	12,8	11,2

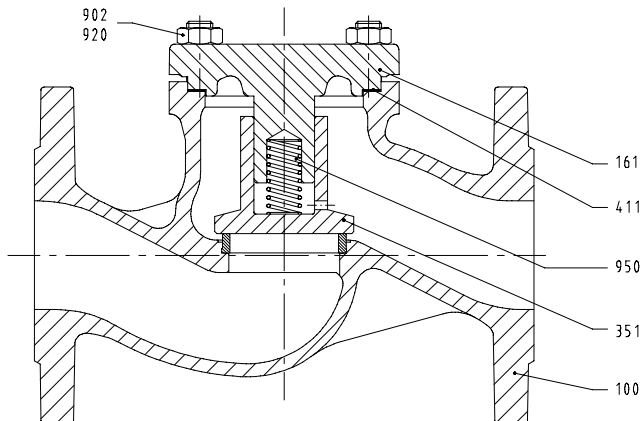
Materials

Overview of available materials

Part No.	Description	PN	DN	Material	Material number
100	Body ⁵⁾	6/16	15-300	EN-GJL-250	JL 1040
		16	15-300	EN-GJS-400-18-LT	JL1025
161	Body cover	6/16	15-300	EN-GJL-250	JL 1040
		16	15-300	EN-GJS-400-18-LT	JL 1025
351	Check disc	6	15-150	X 20 CR 13	1.4021
		16	15-150		
		6	200	St, sealing surface C22/ X 15 CrNi 18 8	1.0402/1.4370
		16	200-350	guide pin X 20 Cr 13	1.4021
411	Joint ring			CrNiSt/graphite	
515	Seat ring			Stainless steel	
902	Stud			C 35 E	
920	Hexagon nut			C 35	
950	Spring			X 12 CrNi 17 7	1.4310

- 1) Intermediate temperatures can be derived by linear interpolation.
- 2) Static load
- 3) DIN EN 12266-1 (P10, P11)
- 4) DIN EN 12266-1 (P12, leakage rate A)
- 5) Body marked "BOA-H"

Valve characteristics

DN 15 to 50

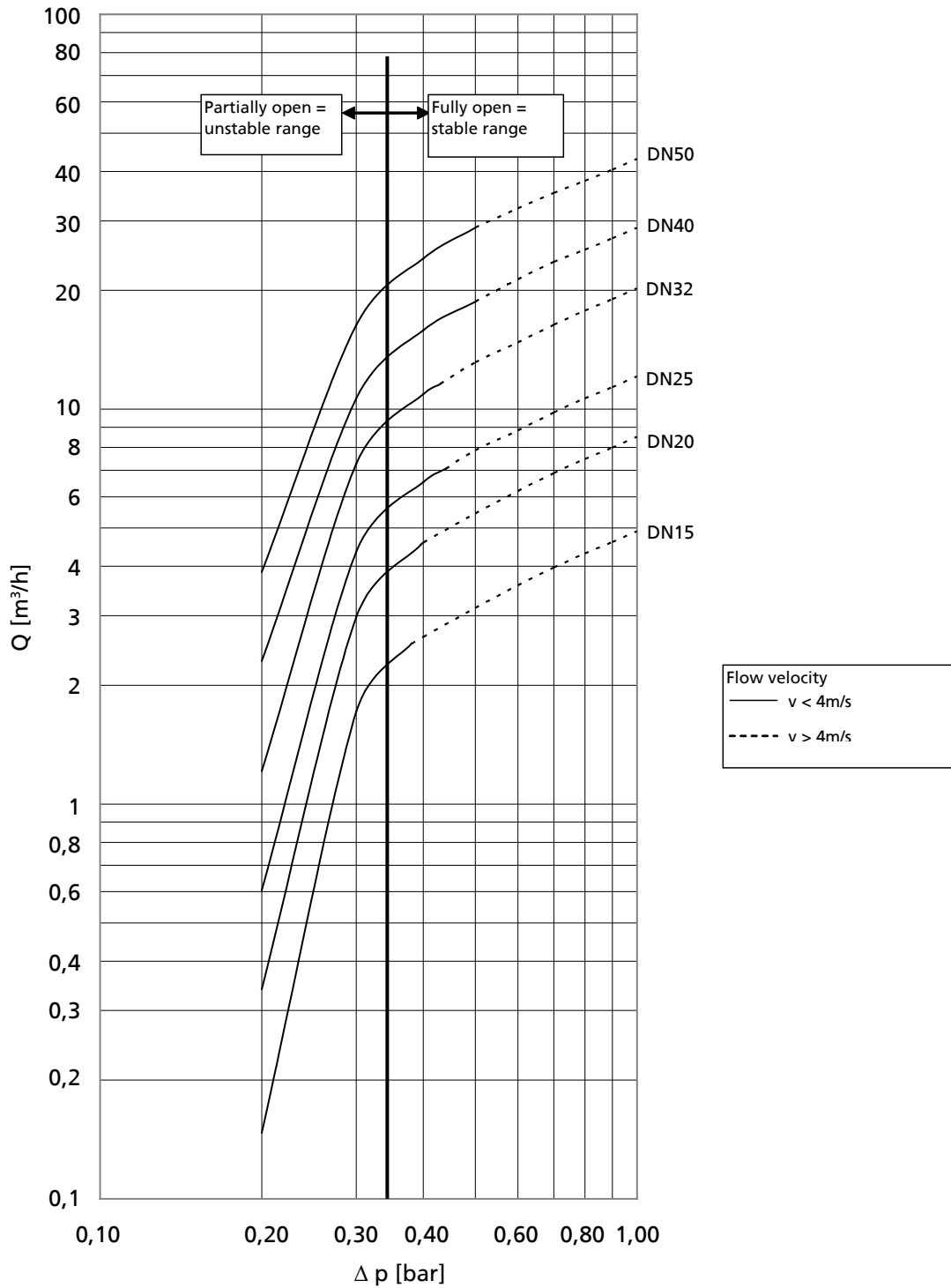

DN 65 to 200

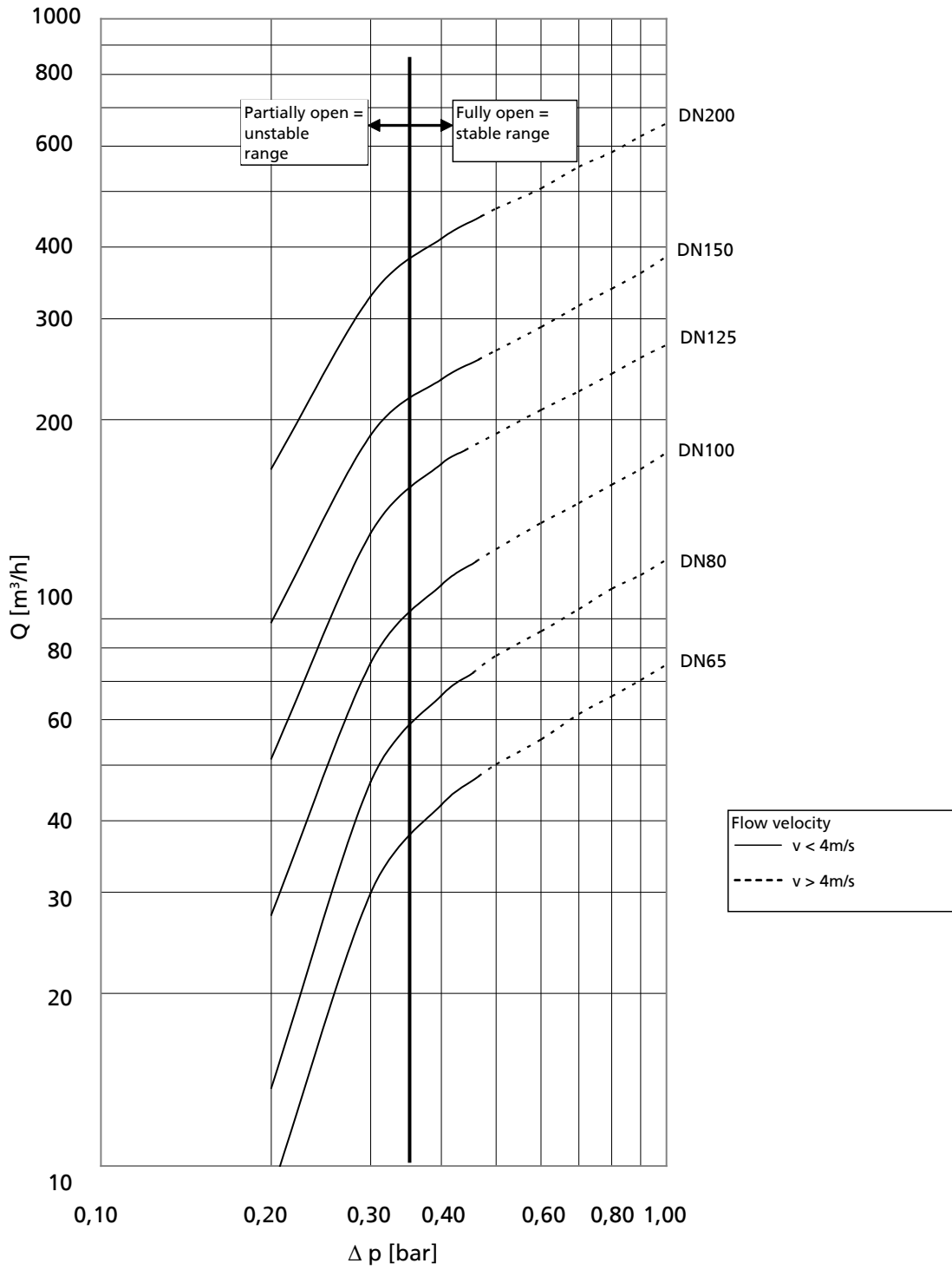

DN 250 to 350

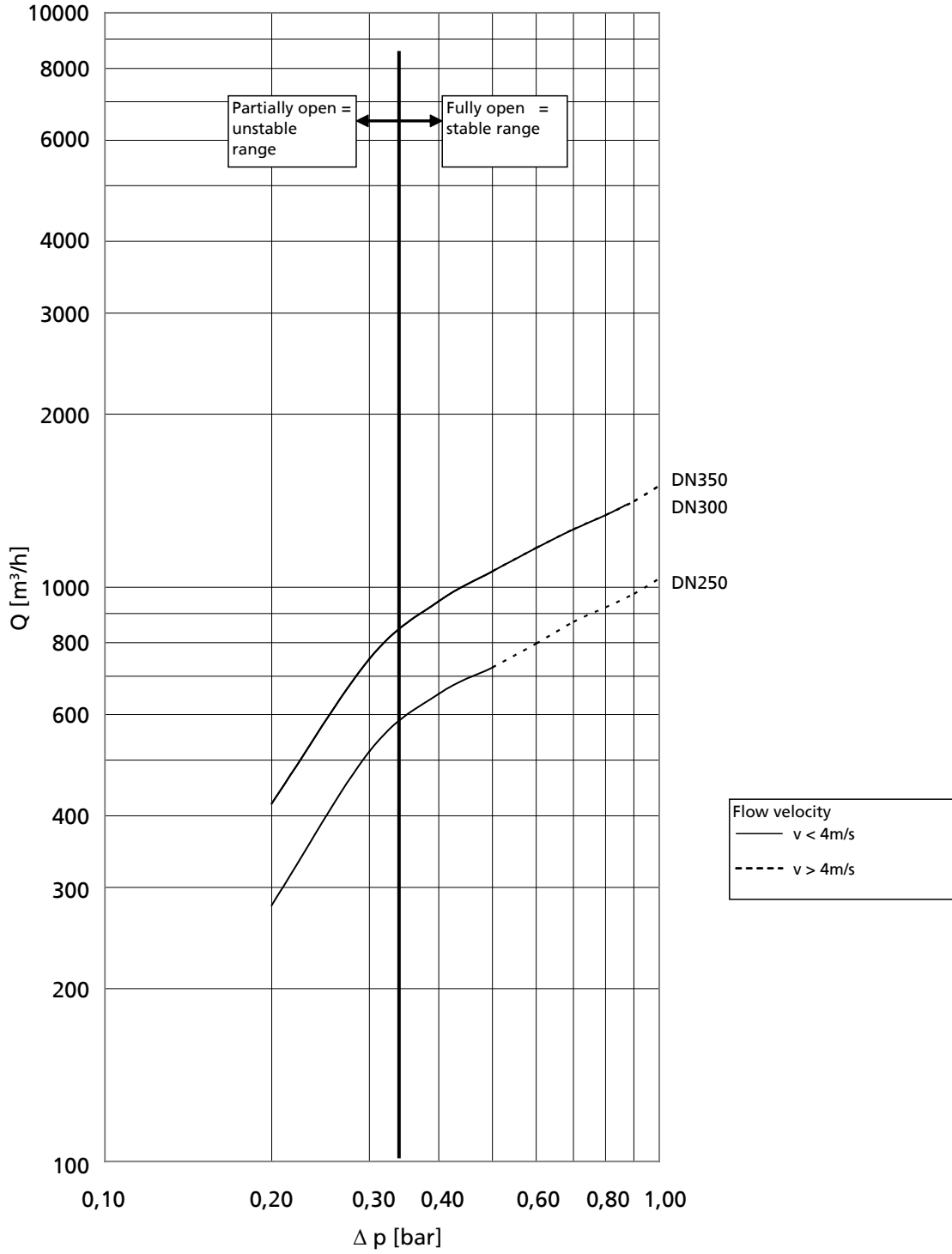

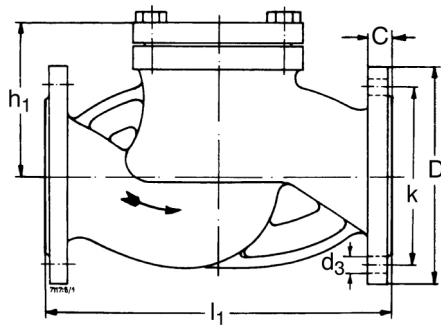
Dimensions

Straight-way valve

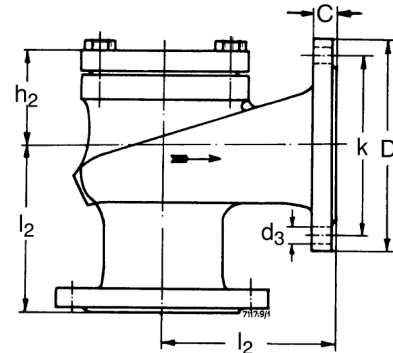

Angle valve

Dimensions in mm

PN	DN	l ₁	l ₂	h ₁	h ₂	D	Ø k	n x d ₃	C	[kg]	
										Straight-way valve	Angle valve
6 ⁶⁾	15	130	-	50	-	95	55	4 x 11	14	2,3	-
	20	150	-	60	-	105	65	4 x 11	16	3,5	-
	25	160	-	65	-	115	75	4 x 11	16	4	-
	32	180	-	85	-	140	90	4 x 14	18	6,9	-
	40	200	-	90	-	150	100	4 x 14	18	8	-
	50	230	-	95	-	165	110	4 x 14	20	10,5	-
	65	290	-	120	-	185	130	4 x 14	20	16,8	-
	80	310	-	130	-	200	150	4 x 19	22	22	-
	100	350	-	155	-	220	170	4 x 19	24	32,5	-
	125	400	-	175	-	250	200	8 x 19	26	52	-
	150	480	-	195	-	285	225	8 x 19	26	72	-
200	600	-	245	-	340	280	8 x 19	30	123	-	
16	15	130	90	50	25	95	65	4 x 14	14	2,3	2,3
	20	150	95	60	35	105	75	4 x 14	16	3,5	3,5
	25	160	100	65	35	115	85	4 x 14	16	4	4
	32	180	105	85	50	140	100	4 x 19	18	6,9	6,7
	40	200	115	90	50	150	110	4 x 19	18	8	7,8
	50	230	125	95	60	165	125	4 x 19	20	10,5	10,5
	65	290	145	120	70	185	145	4 x 19	20	16,8	15,8
	80	310	155	130	75	200	160	8 x 19	22	22	20,5
	100	350	175	155	95	220	180	8 x 19	24	32,5	29,5
	125	400	200	175	105	250	210	8 x 19	26	52	48
	150	480	225	195	110	285	240	8 x 23	26	72	67
	200	600	275	245	140	340	295	12 x 23	30	123	108
	250	730	325	295	150	400	355	12 x 28	32	200	170
300	850	375	335	185	460	410	12 x 28	32	310	262	
350 ⁷⁾	980	-	335	-	520	470	16 x 28	36	357	-	

Mating dimensions - Standards

Face-to-face lengths: Straight-way valve: DIN EN 558 FTF-1, ISO 5752
 Angle valve: DIN EN 558 CTF-8, ISO 5752
 Flanges: DIN EN 1092-2, flange type 21 for JL1040
 DIN EN 1092-2, flange type 21-2 for JS1025
 Flange facing: DIN EN 1092-2, type B

Other flange designs

- Undrilled, DN 200-300 drilled to PN 10, drilled to ANSI Class 150; tongue (type C), groove (type D), spigot (type E), recess (type F) at both ends (to DIN EN 1092-1).
- Other flange designs on request

⁶⁾ PN 6 bolt hole pattern (dimensions k and nxd₃), but flanges dimensioned to PN 16 (dimensions D and b). Please take into account when selecting flange connection bolts.
⁷⁾ DN 350 only in EN-GJS-400-18-LT, straight-way pattern

Installation instructions

i The flow direction must correspond to the arrow indicated on the valve body.

i A minimum pressure is required for opening. If this minimum pressure is not reached, the closing spring can be dismantled. Without closing spring, the valve shall only be installed in upright position in horizontal pipes.

Minimum opening pressures in mbar

DN	15-50	65-150	200-350
with spring	250	200	150
without spring	25	16	22

i EN 1515-4 "Selection of bolting for equipment subject to the Pressure Equipment Directive 97/23/EC" and any plant regulations governing the application in question must be observed when selecting connecting elements between the valve flange and the pipe flange.

Chemical resistance chart

The information provided in this chemical resistance chart is based on experience, the Dechema lists as well as manufacturer information. Corrosion resistance is largely dependent on the operating conditions, temperatures and concentrations. Hydroabrasive wear in fluids containing solids is not covered in this list. All information provided herein, therefore, only serves as an orientation. Warranty claims may not be asserted on the basis of this list!

Chemical resistance chart for water

Fluid handled	Max. content	Max. temp.	A ⁸⁾	B ⁹⁾
Brackish water ¹⁰⁾¹¹⁾			✗	✗
Service water ¹⁰⁾¹¹⁾			✓	✓
Fire-fighting water ¹⁰⁾			✓	✓
Chlorinated water ¹⁰⁾	0,6 mg/kg		✓	✓
Deionised water (demineralised water)			✗	✗
Distilled water			✗	✗
Boiler feed water ¹²⁾			✓	✓
Hot water ¹⁰⁾			✓	✓
High-temperature hot water ¹²⁾		T = f (p)	✓	✓
Condensate ¹²⁾			✓	✓
Oil-free cooling water ¹⁰⁾			✓	✓
Oil-containing cooling water ¹⁰⁾			✓	✓
Ozonised water ¹⁰⁾	0,5 mg/kg		✓	✓
Pure water ¹⁰⁾			✓	✓
Seawater			✗	✗
Scale-forming water ¹⁰⁾¹¹⁾			○	○
Raw water ¹⁰⁾¹¹⁾			✓	✓
Partly desalinated water			✗	✗
Fully desalinated water			✗	✗
Municipal waste water ¹¹⁾¹³⁾			✓	✓
Industrial waste water ¹¹⁾¹⁴⁾			✓	✓

Chemical resistance chart for oils (aromatic content 5 mg/kg)

Fluid handled	Max. content	Max. temp.	A ⁸⁾	B ⁹⁾
Vegetable oils			✓	✓
Mineral oils			✓	✓
Synthetic oils			✓	✓
Crude oil			✓	✓
Petroleum			✓	✓
Light fuel oil			✓	✓
Heavy fuel oil			✓	✓
Linseed oil			✓	✓
Oil-water emulsion ¹¹⁾			✓	✓

Fluid handled	Max. content	Max. temp.	A ⁸⁾	B ⁹⁾
Jet fuel			○ ¹⁵⁾	✓
Petrol			○ ¹⁵⁾	✓
Kerosene			○ ¹⁵⁾	✓

Chemical resistance chart for refrigerants

Fluid handled	Max. content	Max. temp.	A ⁸⁾	B ⁹⁾
Ammonium hydroxide	30 %	25 °C	✓	✓
Glycol (ethylene glycol)			✓	✓
Propylene glycol			✓	✓
Water-glycol mixture	50 %	40 °C	✓	✓
Inorganic cooling brine, ph 7,5 inhibited			✓	✓

Chemical resistance chart for thermal oils

Fluid handled	Max. content	Max. temp.	A ⁸⁾	B ⁹⁾
Synthetic thermal oils			✓	✓
Mineral-based thermal oils			✓	✓

Chemical resistance chart for acids

Fluid handled	Max. content	Max. temp.	A ⁸⁾	B ⁹⁾
Hydrochloric acid			✗	✗
Sulphuric acid (pure, techn., concentr.)			✗	✗
Sulphurous acid			✗	✗
Fatty acid			✗	✗
Nitric acid			✗	✗

Chemical resistance chart for cleaning agents

Fluid handled	Max. content	Max. temp.	A ⁸⁾	B ⁹⁾
Lye for bottle rinsers (e.g. P3) ¹¹⁾		≤ 80 °C	○	○
Lye for metal cleaning ¹¹⁾		≤ 80 °C	○	○

Chemical resistance chart for steam

Fluid handled	Max. content	Max. temp.	A ⁸⁾	B ⁹⁾
Saturated steam			○ ¹⁵⁾	✓

Chemical resistance chart for other fluids

Fluid handled	Max. content	Max. temp.	A ⁸⁾	B ⁹⁾
Sodium hydroxide	< 50 %	≤ 50 °C	○	○
Natural gas			✓	✓
Oil-containing compressed air			✓	✓
Dry chlorine		≤ 30 °C	○	✓
Ammonia			✓	✓
Butane (liquefied gas)			✓	✓

8) EN-GJL-250 (JL 1040), Tmax. +300 °C

9) EN-GJS-400-18-LT (JS 1025), Tmax. +350 °C

10) General limits for water to be handled by valves made of non-alloyed materials: pH value 6,5 - 12; chloride ions (Cl) < 150 mg/kg; chlorine (Cl₂) < 0,6 mg/kg.

11) Without solids

12) Water treatment must be in compliance with the guidelines for feed water (e.g. VdTÜV 1466, TRD 611, etc.): pH value ≥ 9,0; O₂ content ≤ 0,02 mg/l

13) Biologically treated

14) Non-corrosive, non-abrasive

15) For safety reasons (ductility) we recommend to use EN-GJS-400-18-LT.

Fluid handled	Max. content	Max. temp.	A ⁸⁾	B ⁹⁾
Aqueous glycerine			✓	✓
Carbon dioxide (gas)			✓	✓
Carbon dioxide (aqueous solution)			✗	✗

Key to the symbols

Symbol	Description
✓	The fluid handled is not normally aggressive toward the materials.
✗	The fluid handled is aggressive toward the materials. Valve cannot be used.
○	The material or valve can only be used under certain operating conditions. Please enquire accordingly stating the operating conditions such as concentration, temperature, pH value and composition of the fluid handled.



KSB Aktiengesellschaft

Bahnhofplatz 1 • 91257 Pegnitz (Germany)

Tel. +49 9241 71-0 • Fax +49 9241 71-1795

E-Mail: valves@ksb.com • www.ksb.com