



**High performance valve
with Nitrile/VITON® elastomer**

DN 80 to 800 (3" to 32")

Pressure class: Class 150

Design in accordance with ASME B16.42 / B16.34

Applications

- Marine,
- Crude Oil, Product Oil, Oily Water.

Working conditions

- The working temperature depends on the media and on the material of the body and seat (see page 2).
- The allowable pressure PS depends on the body material and the working temperature (see page 2).
- Operating under differential pressure $\Delta P = 16$ Bar Max.
- Vacuum service down to 0 absolute bar.

Materials

Refer to page 2.

Design

- One-piece wafer type body (Type 1)
- One-piece full lug type body (type 4).
- Two interchangeable seats: FKM or NBR.
- Double-eccentric kinematics.
- Upstream/downstream sealing: refer to page 3.
- Face-to-face in accordance with EN 558, ISO 5752 series 20 (except DN 350: ISO 5752 series 25) and API 609 table 2 standards.

- Actuation mounting plate in accordance with ISO 5211 and NF E 29-402 standards.
- Flange facing: stock finish.
- Connections according to EN 1092-1 PN 10 and 16, ASME B 16.5 class 150, ASME B16.47 class 150 series A, JIS B2220-5K, 10K and 16K.
For other connections, please consult us.
- Marking in accordance with EN 19 standard.
- Type approval by ABS, CCS, DNV, Lloyd's Register and BV.

Standard variants

- Handle and manual actuator MR
- Hydraulic actuator ACTO, DYNACTO, ENNACTO
- Limit switches AMTROBOX R

Remarks

- Actuator selection 8460.15/.-90
- Operating instructions 8450.810/.-10

Data to be supplied when ordering

- DANAIS 150C valve, in accordance with leaflet no. 8460.1215-10
- Size, materials for body and seat.
- Working conditions : nature of fluid, pressure, temperature.
- Actuation

Materials

Body	Temperature	Code KSB
Ductile iron ASTM A 536 gr. 60-40-18 (only on T1 bodies)	-10 ° C to +100° C	3g
Carbon steel ASTM A 216 gr. WCC / 1.0619 (only on T4 bodies)	-10 ° C to +100° C	1
Shaft		Code KSB
Stainless steel ASTM A 479 gr. 431 / 1.4057	-10 ° C to +100° C	6e
Disc		Code KSB
Stainless steel ASTM A 351 gr. CF 8M / 1.4408	-10 ° C to +100° C	6
Aluminium bronze B148 C95400	-10 ° C to +100° C	2
AMRING® seat		Code KSB
FKM (VITON®)	-5 ° C to +100° C	VD
NBR (Nitrile)	-10 ° C to +100° C	KD

Pressure / temperature

In pressure class 150 (ASTM materials), DANAIS 150C valves meet:

- ASME B16.42 class150 "Standard class" requirements for ductile iron valves and
- ASME B16.34 class 150 "Standard class" requirements for steel valves.

See values in the table below for the allowable working pressure according to the temperature:

Pressure class	Material Body	Working pressure in bar at temperature ° C		
		0	38	100
Class 150	ASTM A 536 gr. 60-40-18	17,2	17,2	16,2
	ASTM A 216 gr. WCC	19,8	19,8	17,7

Kinematics

The compression of the seating disc edge onto the seat is achieved by double-eccentric kinematics. The axis of the shafts is off-set to valve axis and eccentric to pipe axis. This design eliminates the possibility of friction during operation and, as a result ensures long lasting service while maintaining tight shut-off characteristics. These tight shut-off characteristics conform to the most exacting requirements and standards.

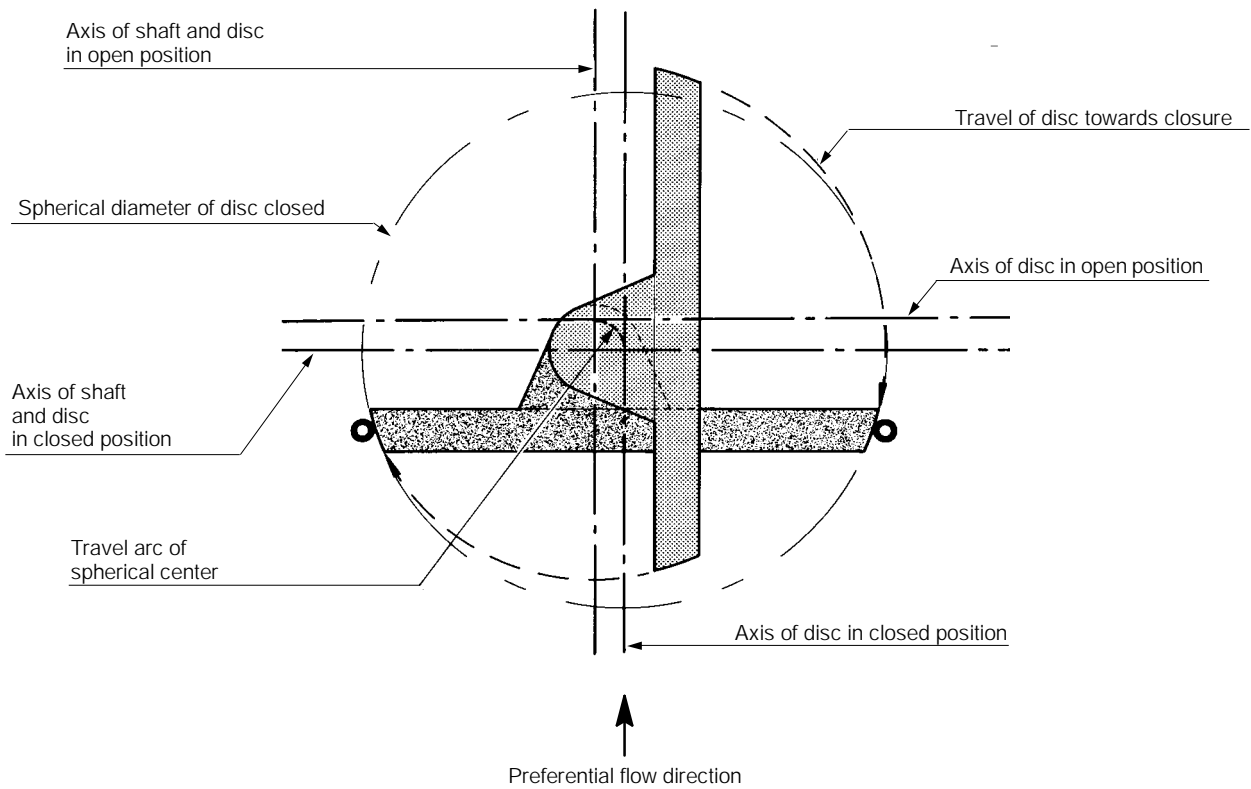

Upstream/downstream sealing

The DANAIS 150C valve conforms to the following sealing standards. The DANAIS 150C valve is a bi-directional valve with a preferential flow direction shown by an arrow (differential pressure direction on the body).

Valve	All seats type
On liquid	EN 12266 category A ISO 5208 category A API 598
On gas	EN 12266 category A ISO 5208 category A API 598 ANSI / FCI 70.2 class VI

Construction

DN 80 to 300 (2" to 12")

Flat shaft end
DN 80 to 200
3" to 8"

Square shaft end
DN 250 and 300
10" and 12"

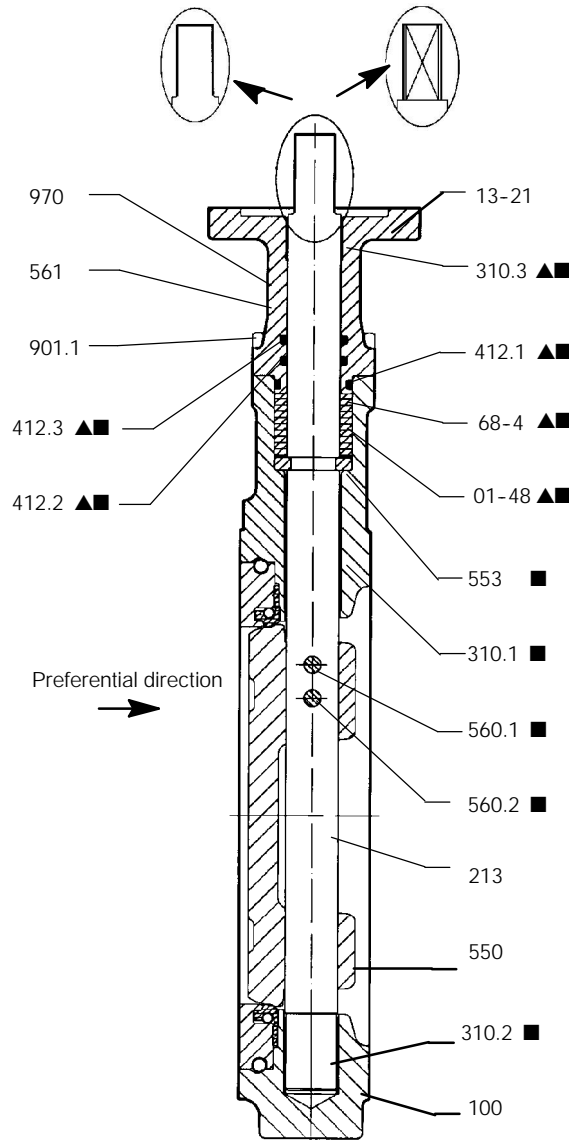

Elastomer seat
FKM or NBR

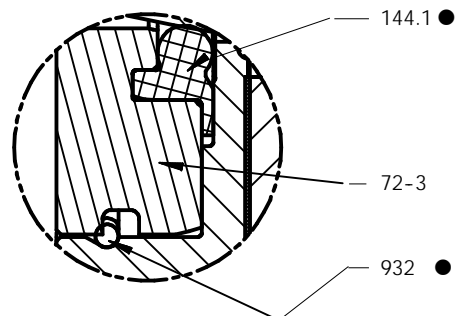

- Spare parts kit for seat
- ▲ Spare parts kit for sealing packing
- Spare parts for guiding

DN 350 to 800 (14" to 32")

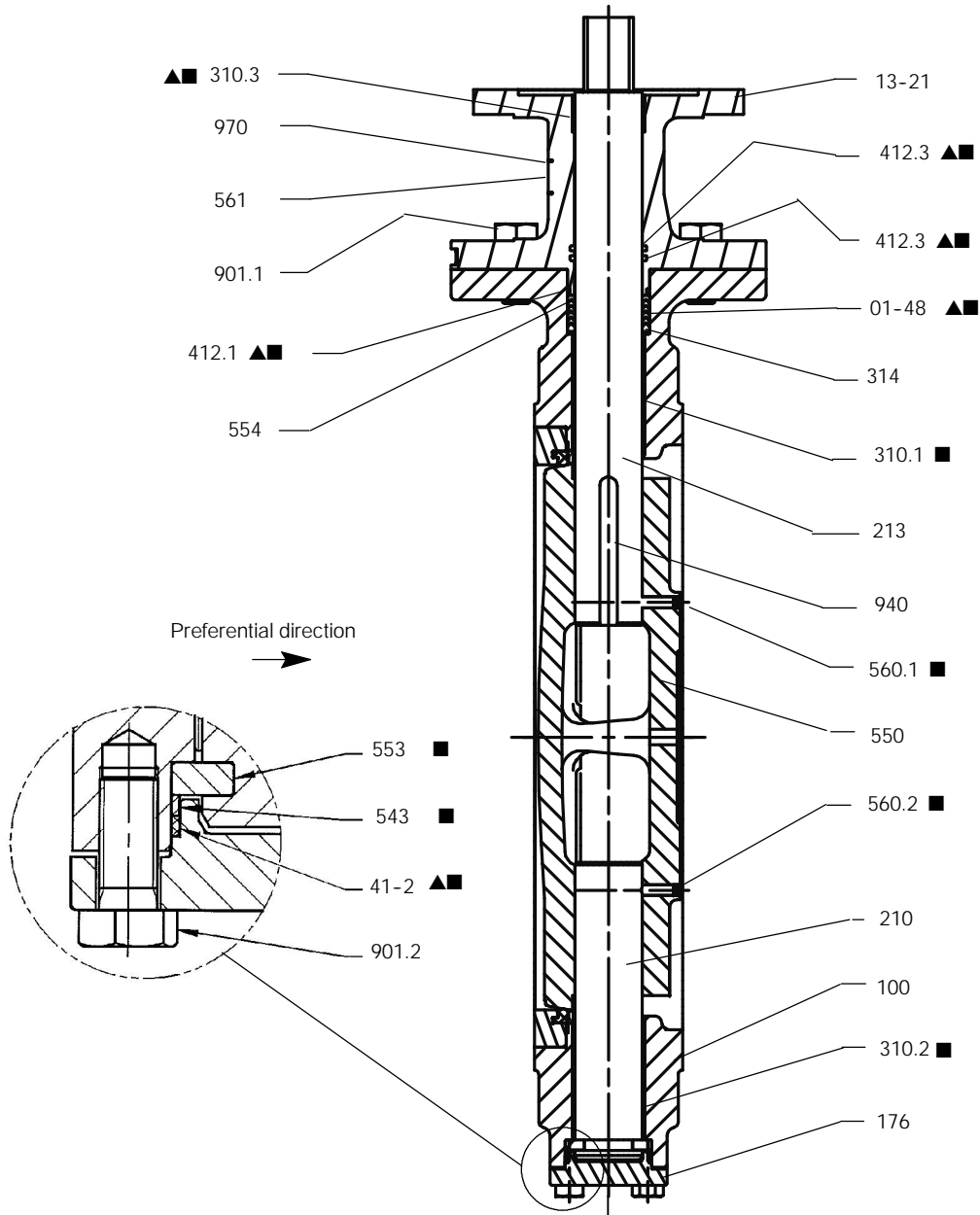

Elastomer seat
FKM or NBR

- Spare parts kit for seat
- ▲ Spare parts kit for sealing packing
- Spare parts for guiding

Parts list

Item	Designation	DN	Materials
Common parts			
01-48	Sealing packing	80 to 800	PTFE
100	Body	80 to 800	Ductile iron ASTM A 536 gr. 60-40-18 Carbon steel ASTM A 216 gr. WCC
13-21	Extension	80 to 800	Ductile iron ASTM A 536 gr. 60-40-18 Stainless steel A351 gr. CF8M
176	Bottom	350 to 800	Ductile iron ASTM A 536 gr. 60-40-18 Stainless steel A351 gr. CF8M / 1.4408
210	Shaft	350 to 800	Stainless steel ASTM A 479 gr. 431
213	Driving shaft	80 to 800	Stainless steel ASTM A 479 gr. 431
310.1	Upper plain bearing	80 to 800	Stainless steel + PTFE
310.2	Lower plain bearing	80 to 800	Stainless steel + PTFE
310.3	Extension plain bearing	80 to 800	Stainless steel +PTFE
314	Thrust washer	350 to 800	Stainless steel
41-2	Static joint	350 to 800	PTFE
412.1	O-Ring	80 to 800	VITON®
412.2	O-Ring	80 to 800	VITON®
412.3	O-Ring	80 to 800	VITON®
543	Spacer bush	350 to 800	Stainless steel
550	Disc	80 to 800	Stainless steel ASTM A 351 gr. CF 8M / 1.4408 Aluminium bronze B148 C95400
553	Upper thrust insert Lower thrust insert	80 to 300 350 to 800	Stainless steel
554	Foil	350 to 800	Stainless steel
560.1	Pin	80 to 800	Stainless steel
560.2	Pin	80 to 800	Stainless steel
561	Grooved nail	80 to 800	Stainless steel
68-4	Foil	80 to 300	Stainless steel
901.1	Hexagon-head screw	80 to 800	A4-70 stainless steel
901.2	Hexagon-head screw	350 to 800	A4-70 stainless steel
940	Key	350 to 800	Stainless steel ASTM A 479 gr. 431
970	Identity plate	80 to 800	Stainless steel
Valve with FKM (VITON®) or NBR (Nitrile) seat			
144.1	Seat	80 to 800	FKM (VITON®) or NBR (Nitrile)
72-3	Tightening flange	80 to 800	Carbon steel
914	Cylindrical-head screw	650 to 800	Stainless steel
932	Inner ring	80 to 600	Stainless steel

Wafer type body Type 1 - Dimensions
DN 50 to 200 (2" to 8")
DN 250 to 400 (10" to 16")

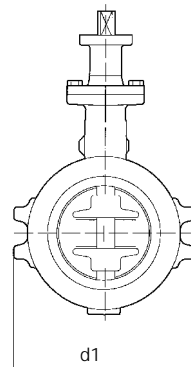
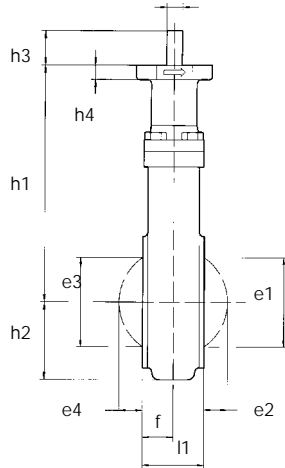
 DN 80 to 200: flat end "s" machined in \varnothing
 DN \geq 250: square end "s"

DN shown: 100 (4")

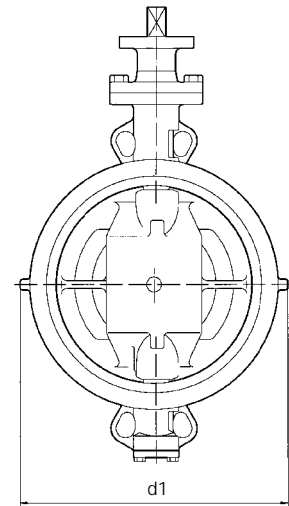

DN shown: 400 (16")

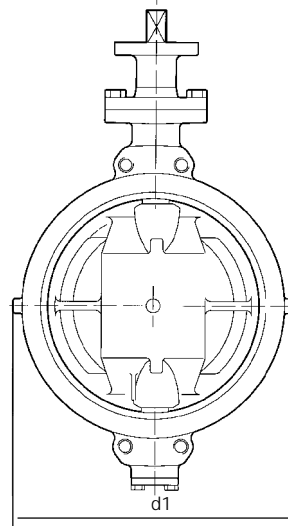
DN 450 (18") to DN 800 (32")

DN shown: 450 (18")

mm

DN	NPS	Face to face l1					Mounting plate according to ISO 5211		Flat shaft end			Square shaft end		Disc clearance			
			d1	h1	h2	f	n°	h4	s	\varnothing z	h3	s	h3	e1	e2	e3	e4
80	3	46	140	185	68	24,0	F05	10	11	14	24			59	13	61	15
100	4	54	180	200	82	27,0	F05	10	14	18	24			78	18	81	21
125	5	57	210	225	92	28,5	F07	12	14	18	30			99	27	103	30
150	6	57	235	240	117	28,5	F07	12	17	22	32			127	39	131	43
200	8	62	271	290	153	34,5	F10	15	19	25	35			177	62	175	59
250	10	70	323	335	182	38,0	F12	18				25	45	225	82	230	80
300	12	80	380	365	230	42,0	F12	18				27	45	265	96	266	98
350	14	92	449	435	307	47,5	F14	22				30	55	308	112	311	116
400	16	102	505	465	332	56,5	F14	22				36	55	359	133	358	132
450	18	114	570	530	371	61,0	F16	26				40	65	418	155	418	160
500	20	127	621	560	398	65,5	F16	26				40	65	455	167	455	175
550	22	146	635	634	422	73	F25	28				50	65	495	189	489	179
600	24	154	730	660	455	77	F25	28				50	65	546	201	546	211
650	26	165	740	720	511	82,5	F25	28				50	80	585	216	590	226
700	28	165	798	750	537	82,5	F25	28				60	80	625	237	630	247
750	30	190	867	780	569	95	F30	34				60	80	689	255	659	243
800	32	190	903	810	599	95	F30	34				70	110	722	274	728	286

Full lug type body Type 4 - Dimensions

DN 80 to 300 (2" to 12")
DN 350 to 800 (14" to 32")

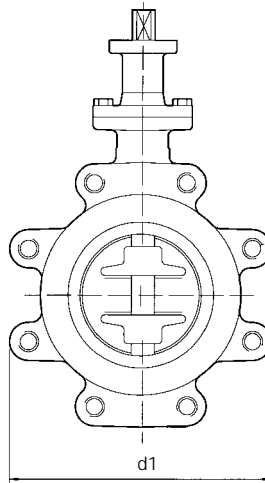
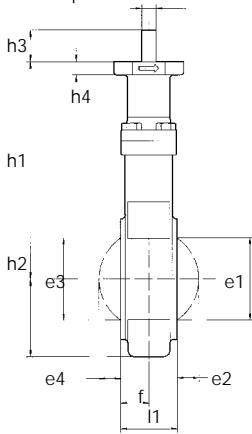
 DN 80 to 200: flat end "s" machined in øz
 DN ≥ 250: square "s"

DN shown: 100

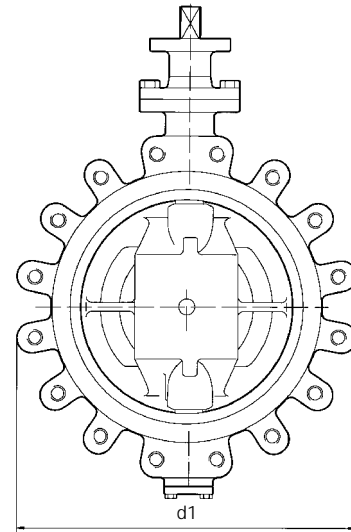

DN shown: 400

mm

DN	NPS	Face to face l1	Mounting plate according to ISO 5211				Flat shaft end			Square shaft end		Disc clearance					
			d1	h1	h2	f	n°	h4	s	øz	h3	s	h3	e1	e2	e3	e4
80 (3)	3	46	136	185	70	24,0	F05	10	11	14	24			59	13	61	15
80 (4)	3	46	176	185	89	24,0	F05	10	11	14	24			59	13	61	15
100	4	54	206	200	104	27,0	F05	10	14	18	24			78	18	81	21
125	5	57	240	225	121	28,5	F07	12	14	18	30			99	27	103	30
150 (1)	6	57	267	240	135	28,5	F07	12	17	22	32			127	39	131	43
150 (2)	6	57	288	240	145	28,5	F07	12	17	22	32			127	39	131	43
200 (5)	8	62	310	290	157	34,5	F10	15	19	25	35			177	62	175	59
200 (6)	8	62	338	290	169	34,5	F10	15	19	25	35			177	62	175	59
250	10	70	410	335	205	38,0	F12	18				25	45	225	82	230	80
300 (7)	12	80	460	365	230	42,0	F12	18				27	45	265	96	266	98
300 (8)	12	80	470	365	235	42,0	F12	18				27	45	265	96	266	98
350 (3)	14	92	508	435	307	47,5	F14	22				30	55	308	112	311	116
350 (4)	14	92	529	435	307	47,5	F14	22				30	55	308	112	311	116
400	16	102	593	465	332	56,5	F14	22				36	55	359	133	358	132
450 (3)	18	114	620	530	371	61,0	F16	26				40	65	418	155	418	160
450 (4)	18	114	649	530	371	61,0	F16	26				40	65	418	155	418	160
500	20	127	705	560	398	65,5	F16	26				40	65	455	167	455	175
550	22	146	635	634	422	73,0	F25	30				50	65	495	189	489	179
600	24	154	822	660	455	77,0	F25	30				50	65	546	201	546	211
650	26	165	873	720	511	82,5	F25	30				50	80	585	216	590	226
700	28	165	895	750	537	82,5	F25	30				60	80	625	237	630	247
750	30	190	970	780	569	95,0	F25	30				60	80	689	255	659	243
800	32	190	1010	810	599	95,0	F25	30				70	110	722	274	728	286

- (1) Mounting between flanges EN 1092-1 PN 10 and 16 - 4 holes, ASME B16.5 cl.150 and JIS B2220-5K, 10K
- (2) Mounting between flanges EN 1092-1 PN 10 and 16 - 8 holes and JIS B2220-16 K
- (3) Mounting between flanges ASME B16.5 cl.150
- (4) Mounting between flanges EN 1092-1 PN 10 and 16 and JIS B2220-5K, 10K and 16K
- (5) Mounting between flanges EN 1092-1 PN 10 and 16 and ASME B16.5 cl.150 and JIS B2220-5K, 10K
- (6) Mounting between flanges JIS B2220-16K
- (7) Mounting between flanges EN 1092-1 PN 10 and ASME B16.5 cl.150
- (8) Mounting between flanges EN 1092-1 PN 16 and JIS B2220-5K, 10K and 16K

Operating torques

Nm

DN	NPS	Preferential direction			Non preferential direction		
		Differential pressure ΔP in bar			Differential pressure ΔP in bar		
		6	10	16	6	10	16
80	3	30	40	40	30	30	40
100	4	50	50	60	40	50	60
125	5	70	80	90	60	70	90
150	6	100	110	140	90	110	140
200	8	160	180	230	150	190	240
250	10	290	340	440	270	350	470
300	12	400	470	620	380	500	680
350	14	610	720	970	570	780	1 080
400	16	820	980	1 340	780	1 060	1 490
450	18	1 130	1 370	1 880	1 080	1 480	2 090
500	20	1 380	1 680	2 310	1 320	1 820	2 570
550	22	1 820	2 220	3 100	1 740	2 450	3 510
600	24	2 210	2 720	3 820	2 130	3 000	4 320
650	26	2 560	3 180	4 480	2 970	4 050	5 660
700	28	2 900	3 630	5 130	3 810	5 090	7 000
750	30	3 600	4 490	6 395	4 530	6 390	8 950
800	32	4 300	5 350	7 660	5 460	7 410	10 340

* The safety coefficient to define the adapted actuator is included in the torque value.

Hydraulic characteristics

DN	NPS	Flow coefficient in fully open position		Zeta
		Kv_0	Cv_0	
80	3	190	220	1,81
100	4	340	400	1,38
125	5	600	700	1,08
150	6	980	1 150	0,84
200	8	1 850	2 150	0,75
250	10	3 350	3 880	0,56
300	12	4 870	5 650	0,55
350	14	7 070	8 200	0,48
400	16	10 350	12 000	0,38
450	18	12 500	14 500	0,42
500	20	15 090	17 500	0,44
550	22	18 750	21 750	0,42
600	24	22 410	26 000	0,41
650	26	24 655	28 600	0,47
700	28	26 900	31 200	0,53
750	30	29 675	34 423	0,57
800	32	38 000	44 100	0,45

Standard variants

ACTO hydraulic actuator

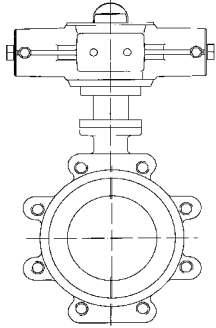

ACTO hydraulic actuator + AMTROBOX R

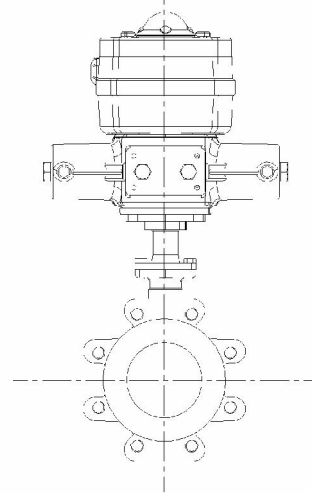

MR manual actuator

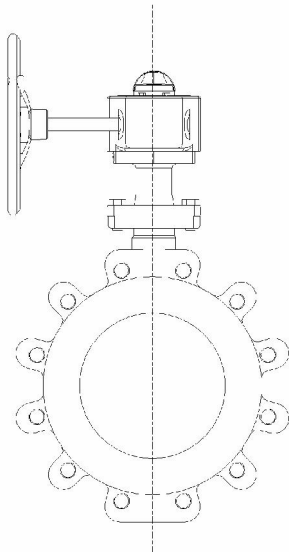

MR manual actuator + AMTROBOX R

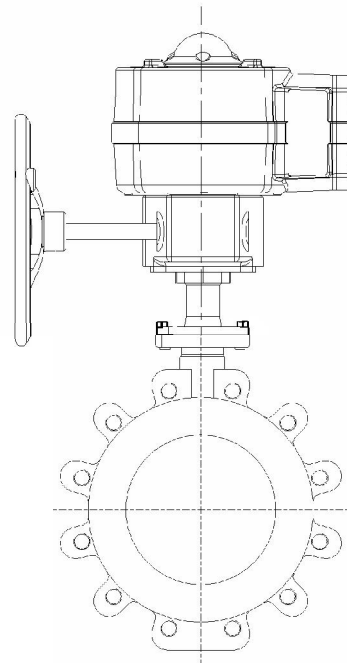

CR handle

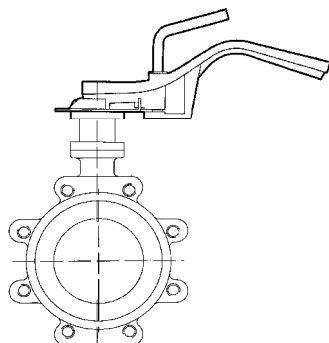

Connections

The table below defines the possible connections. Please consult us for other connections.

Wafer type body - Type 1 -

DN	NPS	EN 1092-1		ASME B16.5 cl.150 B16.47 series A DN >600	JIS B2220		
		PN 10	PN 16		5K	10K	16K
80	3	✓	✓	✓	✓	✓	✓
100	4	✓	✓	✓	✓	✓	✓
125	5	✓	✓	✓	✓	✓	✓
150	6	✓	✓	✓	✓	✓	✓
200	8	✓	✓	✓	✓	✓	✓
250	10	✓	✓	✓	✓	✓	✓
300	12	✓	✓	✓	✓	✓	✓
350	14	✓	✓	✓	✓	✓	✓
400	16	✓	✓	✓	✓	✓	✓
450	18	✓●	✓●	✓●	✓●	✓●	✓●
500	20	✓●	✓●	✓●	✓●	✓●	✓●
550	22			✓●	✓●	✓●	✓●
600	24	✓●	✓●	✓●	✓●	✓●	✓●
650	26			✓●	✓●	✓●	✓●
700	28	✓●	✓●	✓●	✓●	✓●	✓●
750	30			✓●	✓●	✓●	✓●
800	32	✓●	✓●	✓●	✓●	✓●	✓●

Lug type body - Type 4 -

DN	NPS	EN 1092-1		ASME B16.5 cl.150 B16.47 series A DN >600	JIS B2220		
		PN 10	PN 16		5K	10K	16K
80	3	✓	✓	✓	✓	✓	✓
100	4	✓	✓	✓	✓	✓	✓
125	5	✓	✓	✓	✓	✓	✓
150	6	✓	✓	✓	✓	✓	✓
200	8	✓	✓	✓	✓	✓	✓
250	10	✓	✓	✓	✓	✓	✓
300	12	✓	✓	✓	✓	✓	✓
350	14	✓	✓	✓	✓	✓	✓
400	16	✓	✓	✓	✓	✓	✓
450	18	✓	✓	✓	✓	✓	✓
500	20	✓	✓	✓	✓	✓	✓
550*	22			✓	✓	✓	✓
600	24	✓	✓	✓	✓	✓	✓
650	26			✓	✓	✓	✓
700	28	✓	✓	✓	✓	✓	✓
750	30			✓	✓	✓	✓
800	32	✓	✓	✓	✓	✓	✓

* Please, consult us.



Connection allowed



Connection allowed - Threaded holes at shaft passages



The standard does not exist

Face-to-face dimensions

The face-to-face dimensions of DANAIS 150C valve are in accordance with the following standards.

DN	NPS	Wafer type and lug type
80 to 300 and 400 to 600	3" to 12" and 16" to 24"	EN 558-1 series 20 ; API 609 table 2 class 150 and ISO 5752 series 20
350	14"	EN 558-1 series 20 ; API 609 table 2 class 150 and ISO 5752 series 25
650 to 800	26" to 32"	EN 558-1 series 20 ; API 609 table 2 class 150 and ISO 5752 series 20

End of line and downstream dismantling

Use as end of line and downstream dismantling of the standard valves type 4 at room temperature for DN and the differential pressure (ΔPS) are defined hereafter.

End of line and downstream dismantling not allowed for wafer type body - Type 1.

Steel valves:

DANAIS 150C	Gas or liquids*		Liquids	
	Hazardous	Non hazardous	Hazardous	Non hazardous
class 150	All DN: on request	All DN: $\Delta PS = 15 \text{ bar max.}$	All DN: $\Delta PS = 15 \text{ bar max.}$	All DN: $\Delta PS = 15 \text{ bar max.}$

Ductile iron valves:

DANAIS 150C	Gas or liquids*		Liquids	
	Hazardous	Non hazardous	Hazardous	Non hazardous
class 150	All DN: on request	All DN: $\Delta PS = 12 \text{ bar max.}$	All DN: $\Delta PS = 12 \text{ bar max.}$	All DN: $\Delta PS = 12 \text{ bar max.}$

* Liquids having a vapour pressure at the maximum allowable temperature of not more than 0,5 bar above atmospheric pressure (1013 mbar).

ΔPS Differential pressure

NB: A valve fitted at the end of a pipe with a blind flange downstream is not to be considered as an end of pipe service.

Downstream dismantling

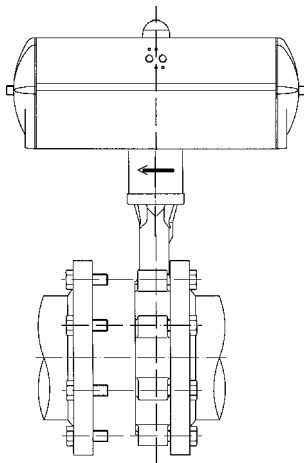

End of line

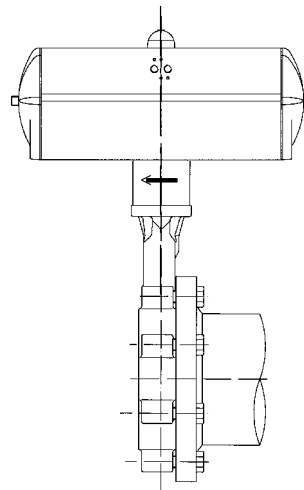

Flange sealing

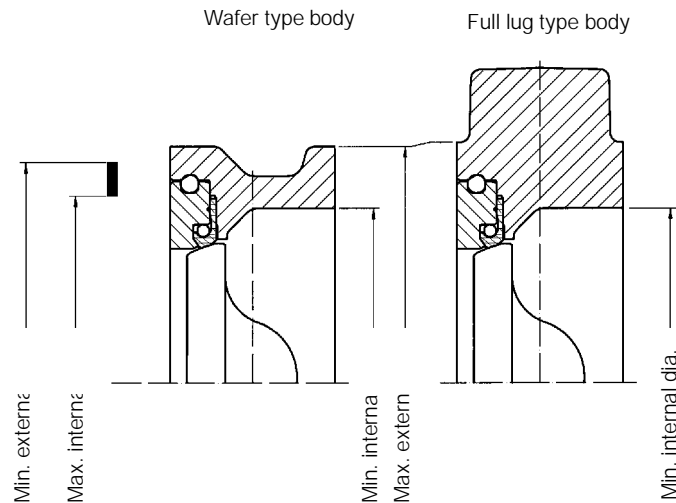

mm

DN	NPS	Flange sealing					Connections	
		Min. area		Max. area			T1	T4
		Max. internal dia.	Min. external dia.	Min internal dia.	Max. external dia.	Wafer type		
80	3	101,2	116,6	91,0	125,0	126,0	ASME B16.5 cl150	
						131,0	PN 10/16 - JIS 5K/10K/16K	
100	4	126,6	142,6	117,0	154,0	156,5	All	
125	5	153,6	169,6	144,0	183,0	185,0		
150	6	180,6	199,1	171,0	214,0	215,0		
200	8	231,5	253,5	222,0	267,0	269,0	PN 10 - ASME B16.5 cl150	
						265,0	PN 16 - JIS 5K/10K/16K	
250	10	286,9	305,5	275,0	321,5	323,0	All	
300	12	339,3	358,5	327,0	377,0	380,0	PN 10/16 - ASME B16.5 cl 150	
						388,0	JIS 5K/10K/16K	
350	14	374,6	400,0	359,0	411,5	412,0	ASME B16.5 cl 150	
						428,0	PN 10/16 - JIS 5K/10K/16K	
400	16	425,9	452,0	410,0	467,5	469,0	All	
450	18	478,5	510,0	461,0	530,5	532,5	All	
500	20	528,0	562,0	512,0	581,5	583,5	All	
550	22	584,0	620,0	556,0	635,0		JIS 5K/10K/16K	
600	24	635,0	671,0	614,0	689,5	691,5	All	
650	26	Please, consult us						
700	28	722,0	756,0	704,0	794,0	794,0	PN 10/16, ASME B16.47 cl.150 series A, JIS 5K/10K/16K	
750	30	776,0	812,0	754,0	853,0	850,0		
800	32	830,0	864,0	804,0	899,0	899,0		

Note: the use of spiral-wound gaskets according to ISO 7483 - PN 10 to 25 is recommended.

Wafer type body - Type 1 - Bolting

The bolting is not supplied

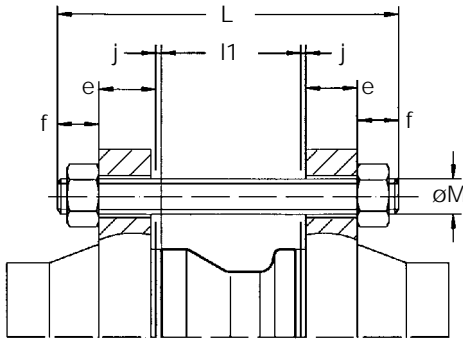

$$L = l1 + 2e + 2f + 2j$$

- L : tie-rod length
- l1 : valve face-to-face
- e : flange thickness
- f : tie-rod overlength
- j : flange gasket thickness

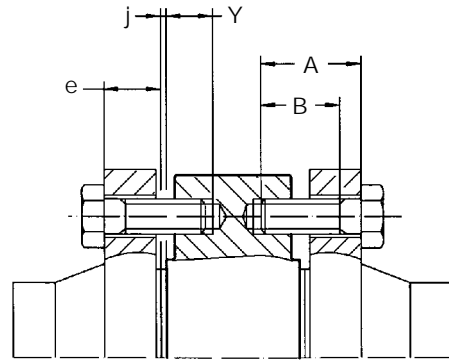

Screws at shaft passages (DN 450)

$$A \text{ max.} = e + Y + j$$

- A max.: screw length
- e : flange thickness
- j : flange gasket thickness
- Y : screw max. implantation
- B : min. threaded length B > A-e

DN	NPS	l1	d1	EN 1092-1 PN 10				EN 1092-1 PN 16				ASME B16.5 cl.150 for DN ≤ 600 ASME B16.47 cl.150 series A for DN > 600				Weight				
				Tie-rod **		Screw A2		øM	Tie-rod*		Screw A2		UNC	Tie-rod*			Screw A2			
				f	Qty	Y	Qty*		f	Qty	Y	Qty*		f	Qty		Y	Qty*		
80	3	46	140	M16	20	8			M16	20	8			5/8"	20	4			4,5	
100	4	54	180	M16	20	8			M16	20	8			5/8"	20	8			6,4	
125	5	57	210	M16	20	8			M16	20	8			3/4"	24	8			9,7	
150	6	57	235	M20	24	8			M20	24	8			3/4"	24	8			12,7	
200	8	62	271	M20	24	8			M20	24	12			3/4"	24	12			22,5	
250	10	70	323	M20	24	12			M24	29	12			7/8"	29	12			34,0	
300	12	80	380	M20	24	12			M24	29	12			7/8"	29	12			48,8	
350	14	92	449	M20	24	16			M24	29	16			1"	32	12			64,5	
400	16	102	505	M24	29	16			M27	32	16			1"	32	16			89,0	
450	18	114	570	M24	29	16	32	4	M27	32	16	31	4	1"1/8	35	12	40	4	133,5	
500	20	127	621	M24	29	16	35	4	M30	35	16	39	4	1"1/8	35	16	39	4	168,0	
550	22																			
600	24	154	730	M27	32	16	40	4	M33	38	16	48	4	1"1/4	38	16	48	4	270,5	
650	26													1"1/4	38	20	39	4	550,0	
700	28	165	798	M27	32	20	39,5	4	M33	38	20	37	4	1"1/4	38	24	33,5	4	400,0	
750	30	190	857	M30	35	20	47	4	M33	38	20	46	4	1"1/4	38	24	42	4	480,0	
800	32	190	903	M30	35	20	47	4	M36	42	20	44	4	1"1/2	45	24	8	4	550,0	

DN	NPS	l1	d1	JIS B2220-5K				JIS B2220-10K				JIS B2220-16K				Weight			
				Tie-rod*		Screw A2		øM	Tie-rod**		Screw A2		øM	Tie-rod**			Screw A2		
				f	Qty	Y	Qty*		f	Qty	Y	Qty*		f	Qty		Y	Qty*	
80	3	46	140	M16	20	4			M16	20	8			M20	24	8			4,5
100	4	54	180	M16	20	8			M16	20	8			M20	24	8			6,4
125	5	57	210	M16	20	8			M20	24	8			M22	26	8			9,7
150	6	57	235	M16	20	8			M20	24	8			M22	26	12			12,7
200	8	62	271	M20	24	8			M20	24	12			M22	26	12			22,5
250	10	70	323	M20	24	12			M22	26	12			M24	29	12			34,0
300	12	80	380	M20	24	12			M22	26	16			M24	29	16			48,8
350	14	92	449	M22	26	12			M22	26	16			M30x3	35	16			64,5
400	16	102	505	M22	26	16			M24	29	16			M30x3	35	16			89,0
450	18	114	570	M22	26	12	40	4	M24	29	16	32	4	M30x3	35	16	32	4	133,5
500	20	127	621	M22	26	16	41	4	M24	29	16	35	4	M30x3	35	16	42	4	168,0
550	22	146	635	M24	29	16	49	4	M30	35	16	47	4	M36x3	42	16	46	4	218,0
600	24	154	730	M24	29	16	39	4	M30	35	20	38	4	M36x3	42	20	41	4	270,5
650	26	165	740	M24	29	20	39	4	M30	35	20	38	4	M36x3	42	20	39	4	350,0
700	28	165	798	M24	29	20	39	4	M30	35	20	38,5	4	M39x3	45	20	37	4	400,0
750	30	190	857	M30	35	20	47	4	M30	35	20	47	4	M39x3	45	20	48	4	480,0
800	32	190	903	M30	35	20	46,5	4	M30	35	24	41	4	M45x3	52	20	45	4	550,0

* Quantity of nuts = quantity of tie-rods x 2

** Quantity of screws by face

Does not exist in the standard

Full lug type body - Type 4 - Bolting

The bolting is not supplied.

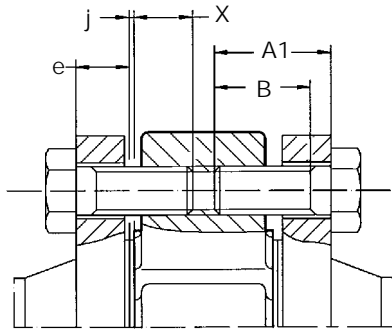

$$A1 \text{ max.} = e + X + j$$

- A1 max.: screw length
- e : flange thickness
- j : flange gasket thickness
- Y : screw max. implantation
- B : min. threaded length $B > A1 - e$

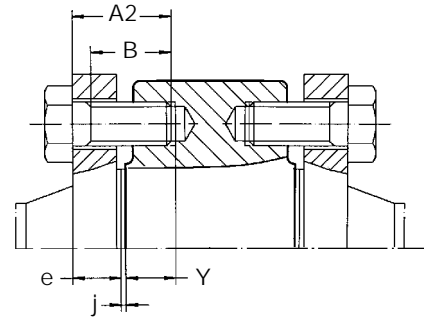

Screws at shaft passages

$$A2 \text{ max.} = e + Y + j$$

- A2 max.: screw length
- e : flange thickness
- j : flange gasket thickness
- Y : screw max. implantation
- B : min. threaded length $B > A2 - e$

DN	NPS	I1	d1	EN 1092-1 PN 10 (1)				EN 1092-1 PN 16 (1)					ASME B16.5 cl.150 for DN ≤ 600 ASME B16.47 cl.150 series A for DN > 600						Weight	
				øM	X	Qty*	Y	Qty*	øM	X	Qty*	Y	Qty*	d1	UNC	X	Qty*	Y		Qty*
80	3	46	136	M16	20	8			M16	22	8			136	5/8"	22	8			7,4
80	3	46	176											176						6,0
100	4	54	206	M16	24	8			M16	24	8			206	5/8"	26	8			10,2
125	5	57	240	M16	24	8			M16	24	8			240	3/4"	27	8			14,6
150	6	57	267	M20	27	8			M20	27	8			267	3/4"	27	8			17,2
200	8	62	310	M20	30	8			M20	30	12			310						25,5
200	8	62	338											338	3/4"	34	12			28,5
250	10	70	410	M20	30	12			M24	34	12			410	7/8"	36	12			44,0
300	12	80	460	M20	30	12			M24	36	12			460						64,8
300	12	80	470											470	7/8"	33	16			68,8
350	14	92	508	M20	30	16			M24	35	16			508	1"	37	16			97,5
350	14	92	529											529						87,7
400	16	102	593	M24	34	16			M27	38	16			593	1"	38	16			130,0
450	18	114	620	M24	32	20			M27	40	16	31	4	620						178,5
450	18	114	649											649	1 1/8"	40	16			163,5
500	20	127	705	M24	35	20			M30	39	20			705	1 1/8"	39	20			218,0
550	22																			
600	24	154	822	M27	40	20			M33	48	20	38	4	822	1 1/4"	48	20			355,0
650	26														ASME B16.47 cl.150 serie A				-	
700	28	165	865	M27	46	20	39,5	4	M33	55	20	37	4	1049	1 1/4"	55	24	34	4	550,0
750	30													970	1 1/4"	55	24	42	4	650,0
800	32	190	1010	M30	50	20	47	4	M36	59	20	44	4	1049	1 1/2"	64	24	38	4	750,0

DN	NPS	I1	d1	JIS B2220-5K				JIS B2220-10K				JIS B2220-16K				Weight				
				øM	X	Qty*	Y	Qty*	øM	X	Qty*	Y	Qty*	øM	X		Qty*	Y	Qty*	
80	3	46	136	M16	20	4			M16	22	8			M20	22	8			6,0	
100	4	54	206	M16	24	8			M16	24	8			M20	26	8			10,2	
125	5	57	240	M16	27	8			M20	27	8			M22	27	8			14,6	
150	6	57	267	M16	27	8			M20	27	8									17,2
150	6	57	288											M22	27	12			20,0	
200	8	62	310	M20	30	8			M20	30	12			M22	30	12			25,5	
250	10	70	410	M20	33	12			M22	33	12			M24	34	12			44,0	
300	12	80	460	M20	33	12			M22	33	16			M24	36	16			64,8	
350	14	92	508	M22	31	12			M22	31	16			M30x3	41	16			87,7	
400	16	102	593	M22	34	16			M24	34	16			M30x3	40	16			130,0	
450	18	114	620	M22	32	16			M24	32	20			M30x3	40	16	32	4	163,5	
500	20	127	705	M22	44	16	41	4	M24	35	20			M30x3	40	16			218,0	
550	22																			
600	24	154	822	M22	46	16	39	4	M30	38	24			M36x3	46	20	41	4	355,0	
650	26	165	873	M24	46	20	39	4	M30	50	20	38	4	M36x3	59	20	39	4	510,0	
700	28	165	798	M24	46	20	39	4	M30	50	20	38,5	4						550,0	
750	30	189,5	950	M30	50	20	47	4	M30	50	20	47	4	Please, consult us				605,0		
800	32	190	1049	M30	50	20	47	4	M30	50	24	41	4					750,0		

* Quantity of screws by face

Product features - to our customer's benefit

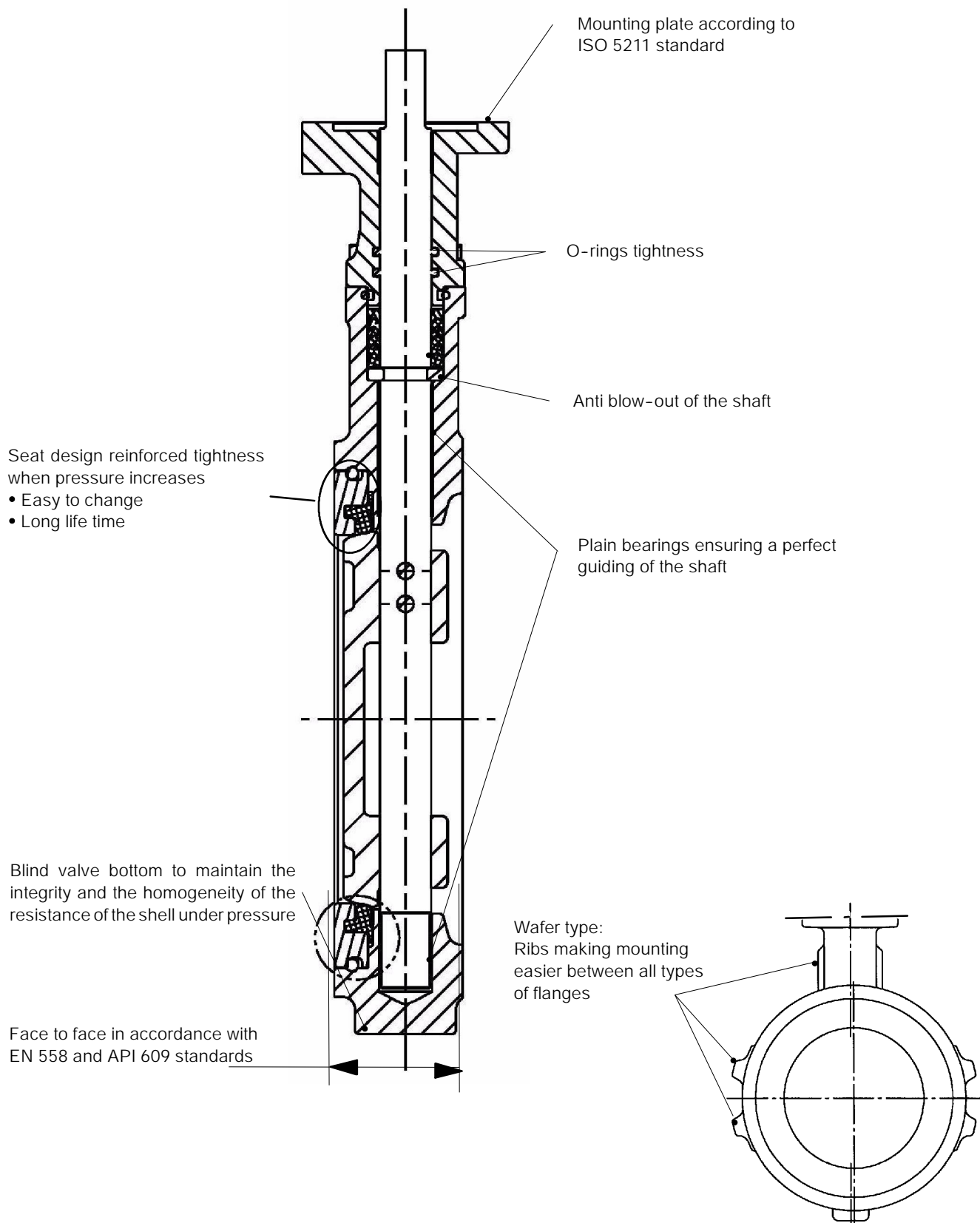

This leaflet is not contractual and may be amended without notice.

30.06.11

8460.1215/5-10