

**Maintenance-free
Diaphragm valve
lined
and
unlined**

with flanges
PN 10
DN 15 - 200
ND 1/2" - 8"

Fields of application

- industrial applications
 - power plants
 - general industries
 - chemical and industrial process engineering
- Suitable for abrasive and aggressive products such as water, drainwater, acids, caustic solution, sludge and suspension.

Operating data

- operating temperature range from -10°C up to +140°C
- operating pressure range from vacuum up to 10 bar

Design

Soft sealing diaphragm valve, straight through type. Sealing in the passage and towards the outside by a diaphragm. Position indicator with integrated stem protection. DN 125 - 200 with threaded bush.

Specifications

valve	- manufactured and tested	EN 13397
	- designated	DIN/EN 19 (ISO 5209)
flange	- dimensions	ASME B 16.5 - 1996 CL.150 DIN EN 1092-2 (BS 4504)
	- surface	ASME B 16.5 - 1996 Cl.150-FF DIN EN 1092-2 Form B (RF)
	face-to-face length	EN 558-1 R7 (ISO 5752/7) (BS 5156)

Inspection

certificate	- material	EN 10204 2.2 EN 10204 3.1
	- final inspection	EN 10204 3.1

SISTO valves comply with the safety requirements of the Pressure Equipment Directive 97/23/EG, fluid group 1+2, modul H.

SISTO valves have no own potential ignition source and can therefore, according to ATEX 94/9/EG, be used in hazardous locations of the group II, category 2 (zone 1+21) and category 3 (zone 2 +22)

Materials

Body	grey cast iron	JL-1040	GJL-250
Bonnet	grey cast iron	JL-1040	GJL-250
Compressor	grey cast iron	JL-1040	GJL-250
Stem	stainless steel		1.4104
Diaphragm		EPDM	+140°C
Screws	steel		A2
Handwheel	cast iron/plastic	JL-1030	ABS

Variants

Body Lining	NR-H	Ebonite	+100°C
	IIR	Butyl	+120°C
Body Coating	PA	Rilsan	+90°C
	ECTFE	Halar	+90°C
Diaphragm Material	IIR		+120°C
	NBR		+90°C
	CSM		+100°C

These data are given as a guide only and do not apply to all operating conditions.

On all inquiries / orders please specify

- | | |
|---------------------------|----------------------------------|
| 1 - type | 7 - medium |
| 2 - PN | 8 - pipe connection |
| 3 - DN | 9 - variants |
| 4 - working pressure | 10 - certificate |
| 5 - differential pressure | 11 - type series booklet- number |
| 6 - operating pressure | |



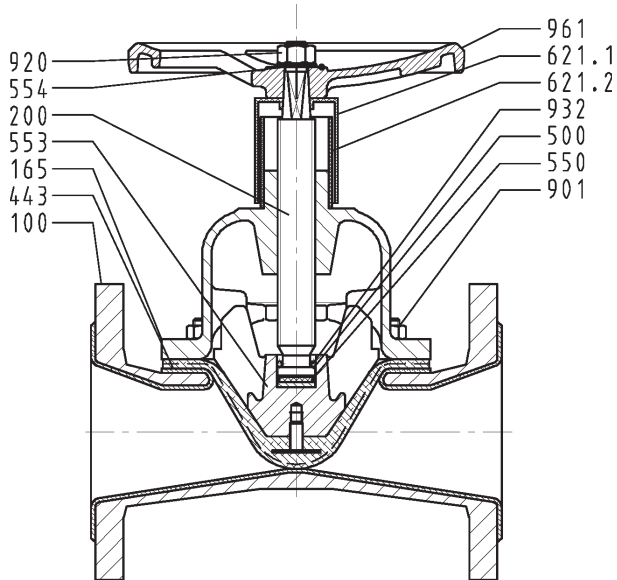

design DN 015-100

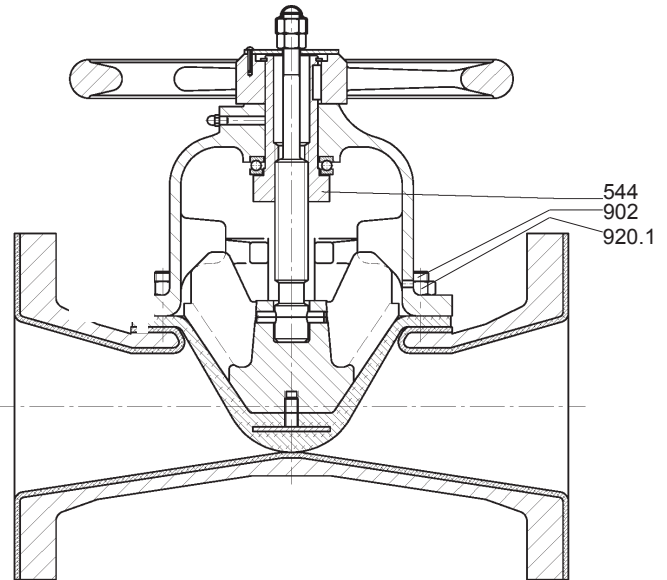
design DN 125 - 200
as variant DN 015 - 100

Item no.	Designation	Material	Note
100	body	JL-1040/NRH	standard
165	bonnet	JL-1040	standard
200	stem	1.4104	
443*	diaphragm	EPDM	standard
500	disc	St A2E	
544	threaded bush	JS-1025	on DN 125 - 200
553	compressor	JL-1040	
554	disc	St A2E	on DN 015 - 100
550	splitting disc	St A2E	on DN 015 - 050
550.1	disc	9S20	on DN 065 - 100
550.2	bearing disc	PTFE/graphite	on DN 050 - 100
560	pin	springsteel	on DN 065 - 100
621.1	upper opening indicator	ABS Luran	
621.2	lower opening indicator	ABS Luran	
901	hexagon nut	A2-70	
902	stud	A2-70	on DN 100 - 200
920	hexagon nut	A2	
920.1	hexagon nut	A2	on DN 100 - 200
932	circlip	springsteel	on DN 015 - 050
961	handwheel	JL-1030	on DN 015 - 020 ABS

recommended spare part*Operating instructions**

0570.821

material limitations

data sheet

8630.165

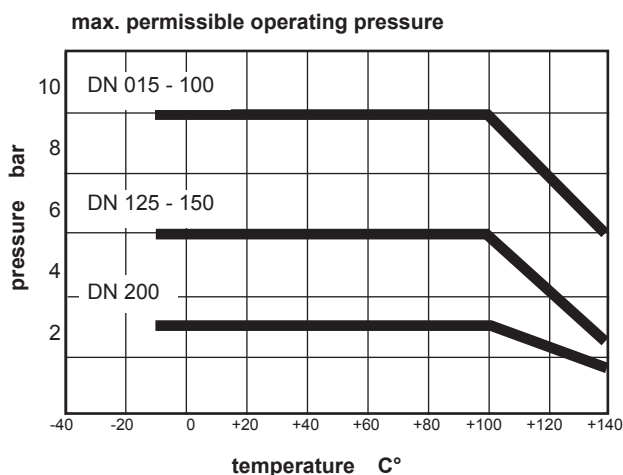

Max. application limit for diaphragm (EPDM)

flow values

DN	Kv-value m ³ /h	DN	Kv-value m ³ /h
015	6,8	065	166
020	11,5	080	227
025	26,0	100	410
032	36,0	125	616
040	57,0	150	1080
050	90,0	200	1879

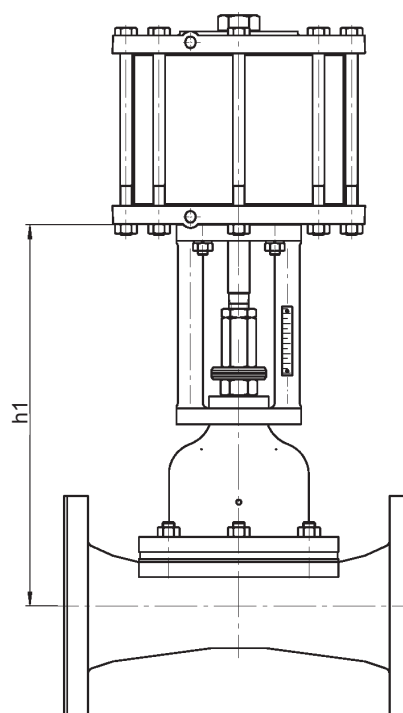
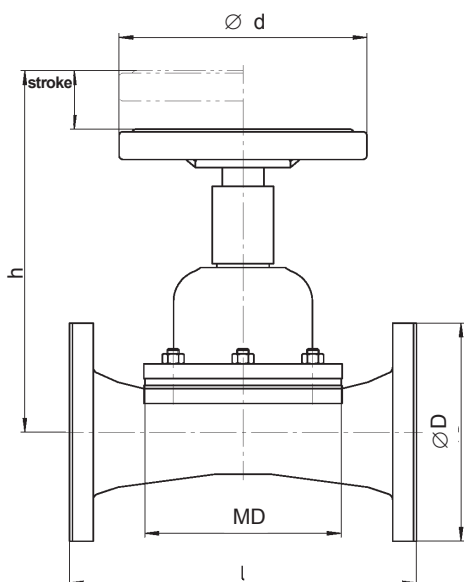

nominal size DN	diaphragm MD Ø/ A x B	face-to-face length l**	flange-diameter Ø D	valve-stroke	manual valve				actuated valve	
					height h*	handwheel Ø d	handwheel turns approx.	weight kg	height h1*	actuator-flanges
015	70 x 46	108	95	9	93	63	3	2,0	216	F10
020	70 x 46	117	105	21	155	100	7	3,5	235	
025	86 x 67	127	115					4,0		
032	86 x 67	146	140					6,5		
040	86 x 67	159	150					7,0		
050	111 x 86	190	165	33	220	125	8	10,3	300	
065	136 x 108	216	185	45	280	200	11	16,0	337	F10
080	169 x 134	254	200	46	320			20,0	362	
100	Ø 198	305	229	59	370	250		26,5	382	
125	Ø 230	356	254	73	360	320	15	55,0	444	
150	Ø 285	406	285	95	440	400	19	75,0	511	
200	Ø 337	521	343	114	560	500	23	125,0	623	F10/F14

SISTOMAT-P

type series booklet 9210.1

all dimensions in mm

SISTOMAT-E-MATE/-LAE

on request

* with rubber lining add. 5 mm

SISTOMAT-PC

type series booklet 8651.1 PC

** with rubber lining add. 6 mm

all moving parts
are separated from the
medium by the diaphragm

thrust bearing
reduces the required closing
torques

opening indicator
with integrated stem protection in-
creases the reliability of operation

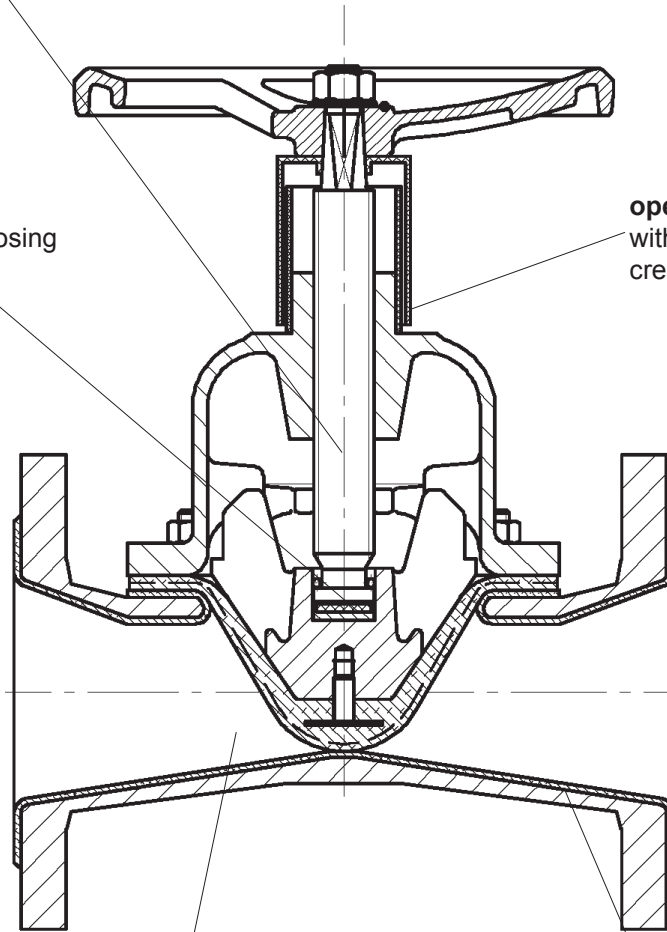

body lining
up to the flange area

hydrodynamic body shape
low flow drag,
no entrapment areas,
no sediments

body on request
- without lining
- with rubber lining
- with plastic coating

This document is not contractual and
may be amended without notice.

8651.101/8-10 / 08.07.2010