

## Applications

- LNG process / All liquefied gases.
- Oil and gas, chemicals, petrochemicals, nuclear industry.
- Compressed gas, Hydrocarbon.

## Working conditions

- Temperature :  
MT versions: from  $-46\text{ }^{\circ}\text{C}$  min. up to  $+260\text{ }^{\circ}\text{C}$  max.  
TBT versions: from  $-196\text{ }^{\circ}\text{C}$  min. up to  $+200\text{ }^{\circ}\text{C}$  max.
- Allowable pressure (PS): depends on the body material and the working temperature, see page 2.
- Operating under  $\Delta P = PS$
- Vacuum service down to 0 absolute bar.
- Maximum fluid velocity under allowable pressure:  
4 m/s for liquids and 50 m/s for clean gases.
- Lower neck extension seal for valve positioned at an angle  
 $\pm 20\text{ }^{\circ}$  from vertical position.

## Materials

See page 2.

## Design

- Full-lug type body with raised faces (Type 4): DN 8" to 24"
- Flanged type body (Type 7): 8" to 24"
- Face-to-face according to:  
Cl. 600 Type 4 -> API 609-B (A) cl. 600,  
Cl. 600 Type 7 -> ISO 5752 serie 14, EN 558.1 serie 14,  
API 609-B (C) cl. 600.
- Marking in accordance with EN 19 standard.
- Steel body: paint grey colour, internal thickness 35  $\mu\text{m}$ ,  
Stainless steel body: pickling and passivation.

- The valves meet the safety requirements of the Pressure Equipments Directive 97/23/EC (PED) Appendix I for fluids of the groups 1 and 2.
- Fire-safe in accordance with ISO 10497.
- Zero leakage, bi-directional.

## Connections

- ASME B16-5 cl. 600 UN/UNC,

## Standard variants

- Pneumatic actuator ACTAIR / DYNACTAIR
- Manual actuator MR
- Hydraulic actuator ACTO / DYNACTO
- Multi turn electric actuator ACTELEC

## Options

- Bottom with purge plug
- Fugitive emission version
- ATEX version in accordance with 94/9/EC directive

## Data to be supplied when ordering

- TRIODIS valve in accordance with type series booklet 8613.1786-EN.
- Size + Type.
- Materials (body, disc, seat).
- Working conditions: nature of fluid, pressure, flow, temperature.
- Connection.
- Flange facing finish and type of contact faces.
- Actuation.



## Materials

### MT Version

Body	KSB code
Steel ASTM A 216 gr. WCC and EN 10213 1.0619 + stellite	1
Steel ASTM A 216 gr. WCB + stellite	1p
Steel ASTM A 352 gr. LCB + stellite	1n
Steel ASTM A 352 gr. LCC and EN 10213 1.6220 + stellite	1m
Stainless steel ASTM A 351 gr. CF8M and EN 10213 1.4408 + stellite	6
Extension	KSB code
Steel ASTM A 216 gr. WCC and EN 10213 1.0619	1
Steel ASTM A 216 gr. WCB	1p
Steel ASTM A 352 gr. LCB	1n
Steel ASTM A 352 gr. LCC and EN 10213 1.6220	1m
Stainless steel ASTM A 351 gr. CF8M and EN 10213 1.4408	6
Shaft	KSB code
Stainless steel AISI 431 and EN 10272 1.4057 (from 0 °C min. up to +260 °C)	6h
Stainless steel ASTM A 564 gr. 630 and EN 10088-3 1.4542 (from -50 °C min. up to + 0 °C)	6e
Disc	KSB code
Steel ASTM A 216 gr. WCC and EN 10213 1.0619	1
Steel ASTM A 216 gr. WCB	1p
Steel ASTM A 352 gr. LCB	1n
Steel ASTM A 352 gr. LCC and EN 10213 1.6220	1m
Stainless steel ASTM A 351 gr. CF8M and EN 10213 1.4408	6
Seat	KSB code
Stainless steel Duplex	7e
Stainless steel Duplex + graphite	7f

Other materials, consult us.

### TBT Version

Body	KSB code
Stainless steel ASTM A 351 gr. CF8M and EN 10213 1.4408 + stellite	6
Extension	KSB code
Stainless steel ASTM A 351 gr. CF8M and EN 10213 1.4408	6
Shaft	KSB code
Stainless steel ASTM A 479 gr. XM19	6r
Stainless steel ASTM A 479 gr. 316L or equivalent (for reduced working pressure)	6
Stainless steel ASTM A 638 gr. 660 (for exceptional working conditions)	6f
Disc	KSB code
Stainless steel ASTM A 351 gr. CF8M and EN 10213 1.4408	6
Seat	KSB code
Stainless steel Duplex	7e
Austenitic Stainless steel XM19	6r
Inconel	8j

Other materials, consult us.

## Pressure / temperature

In pressure class 600 (european materials), TRIODIS 600 valves are in accordance with EN 12516-1 standard and ASME B 16-34.

The values in the table below must be used for valves which have to comply with PED 97/23/CE:

Material Body + extension	Working pressure in bar at temperature ° C									
	-196	-46	-29	-10	50	100	150	200	250	260
ASTM A 216 gr. WCC / EN10213 1.0619	Forbidden	Forbidden	103,4*	103,4	103,4	103	100,3	97,2	92,6	91,2
ASTM A 216 gr. WCB	Forbidden	Forbidden	102,1*	102,1	100,1	92,7	90,2	87,6	83,4	82,2
ASTM A 352 gr. LCB	Forbidden	95,7*	95,7*	95,7	94,6	90,2	87,9	85,1	81,1	79,9
ASTM A 352 gr. LCC / EN10213 1.6220	Forbidden	103,4*	103,4*	103,4	103,4	103	100,3	97,2	92,6	91,2
ASTM A 351 gr. CF8M / EN10213 1.4408	99,3	99,3	99,3	99,3	96,2	84,4	77	71,3	66,8	66

\* Only according to ASME B16-34

## Hydraulic characteristics

DN	NPS	Flow coefficient in full open position		Zeta
		Kv <sub>0</sub>	Cv <sub>0</sub>	
200	8	703	815	5,17
250	10	1318	1528	3,59
300	12	2076	2408	3,00
350	14	2719	3154	3,24
400	16	4159	4824	2,36
450	18	5139	5962	2,48
500	20	6765	7848	2,18
600	24	10073	11685	2,04

**First offset**

the seal is offset from shaft axis to allow upstream/downstream tightness without interference of the shaft passage.

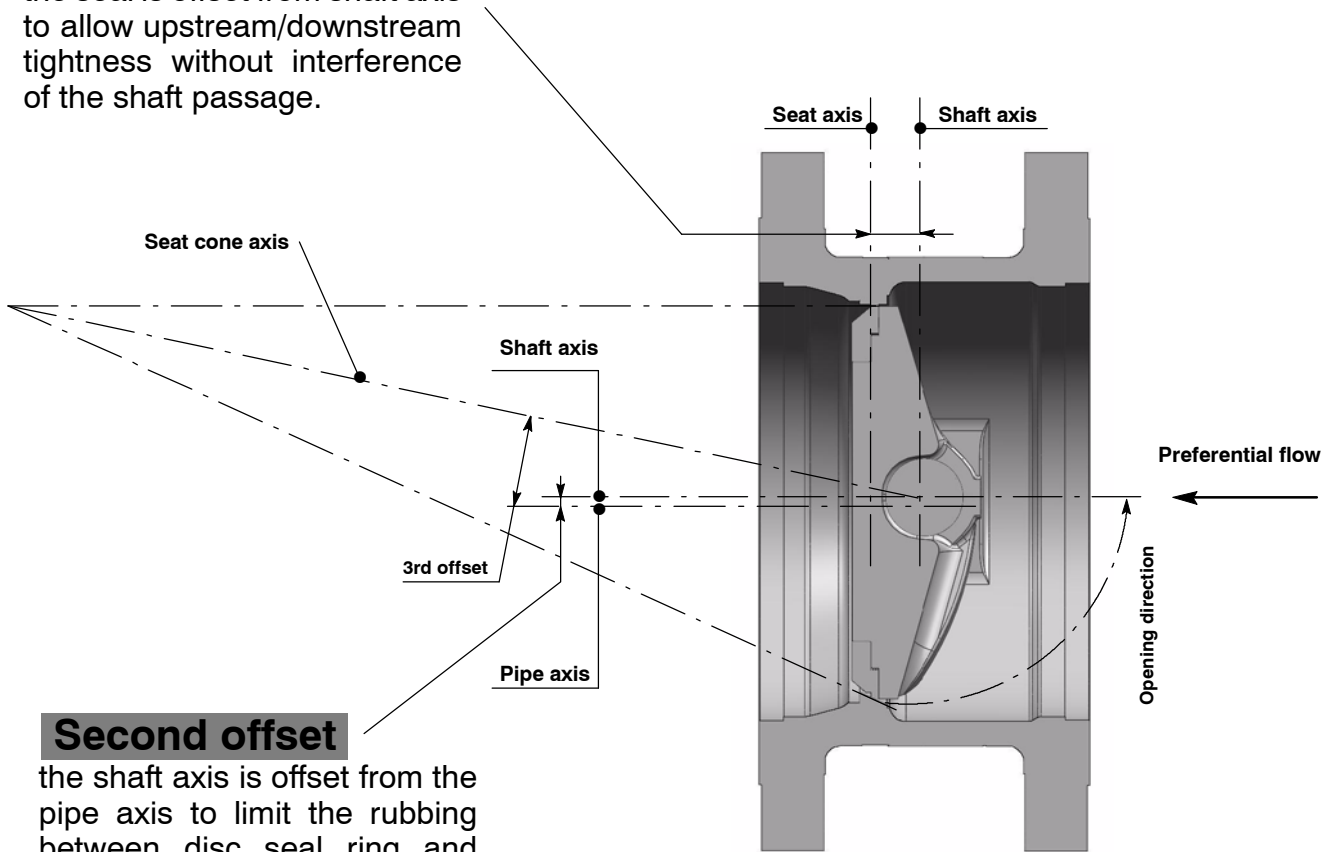

**Second offset**

the shaft axis is offset from the pipe axis to limit the rubbing between disc seal ring and body seat

**Third offset**

the seat cone axis is inclined of a specific angle from pipe axis:  
 - to provide the perfect matching of the sealing conical surfaces so that the valve is bubble tighten at high pressure levels,  
 - to eliminate rubbing during the operating of the valve in order to guarantee a long service life.

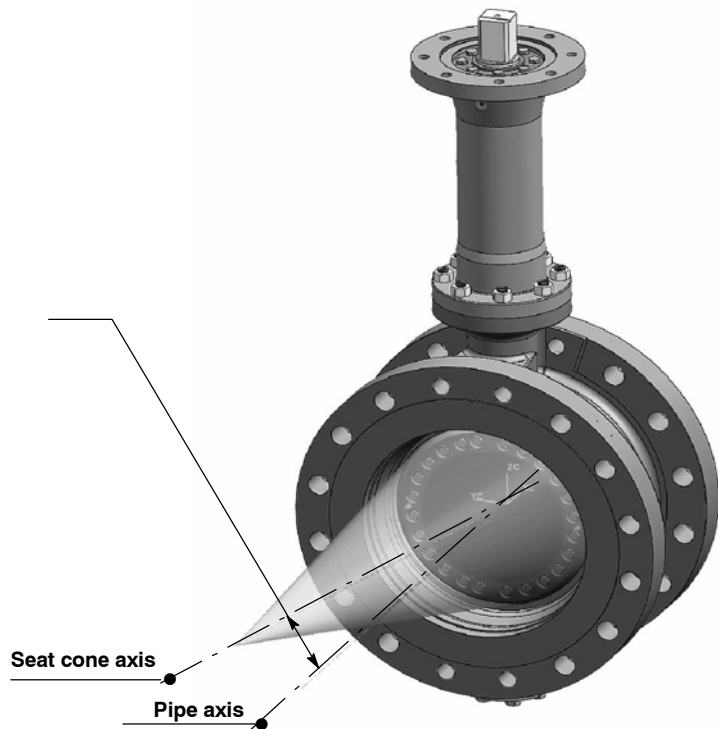

Construction

MT version (Type 7 represented)

Disc drive with splines  
DN 8" and DN 10"

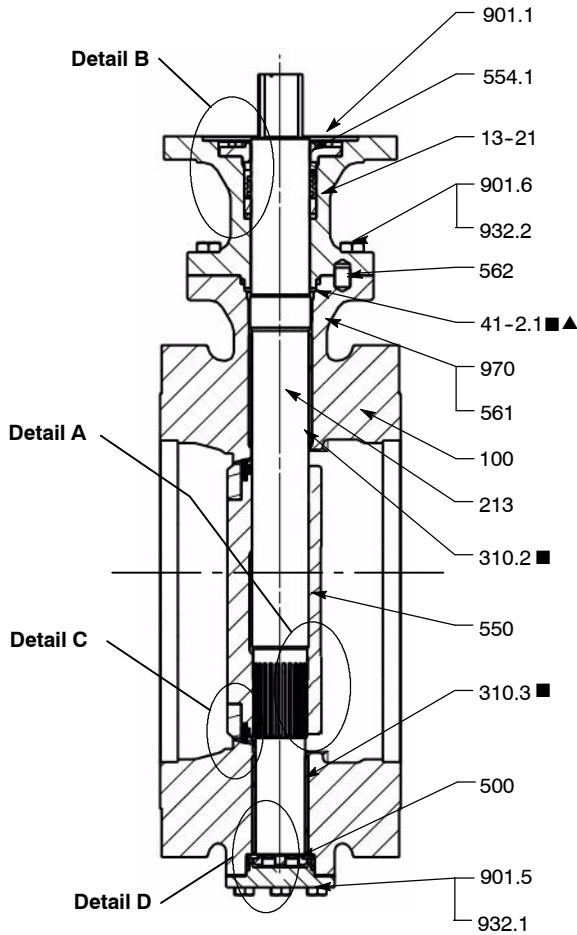

Disc drive with cylindrical keys  
DN 12" to DN 24"

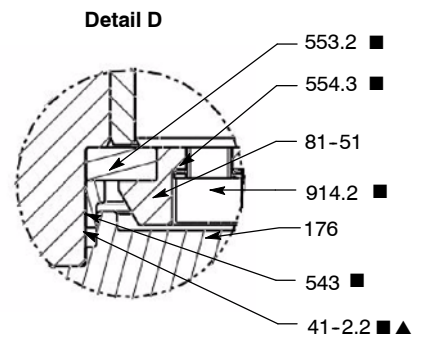
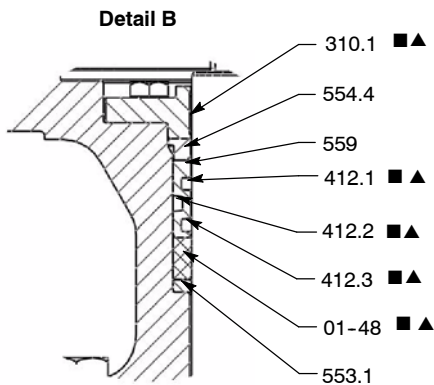
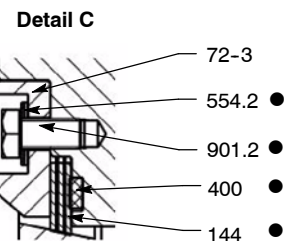
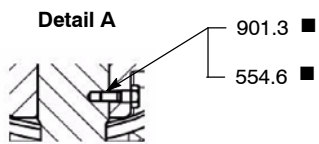
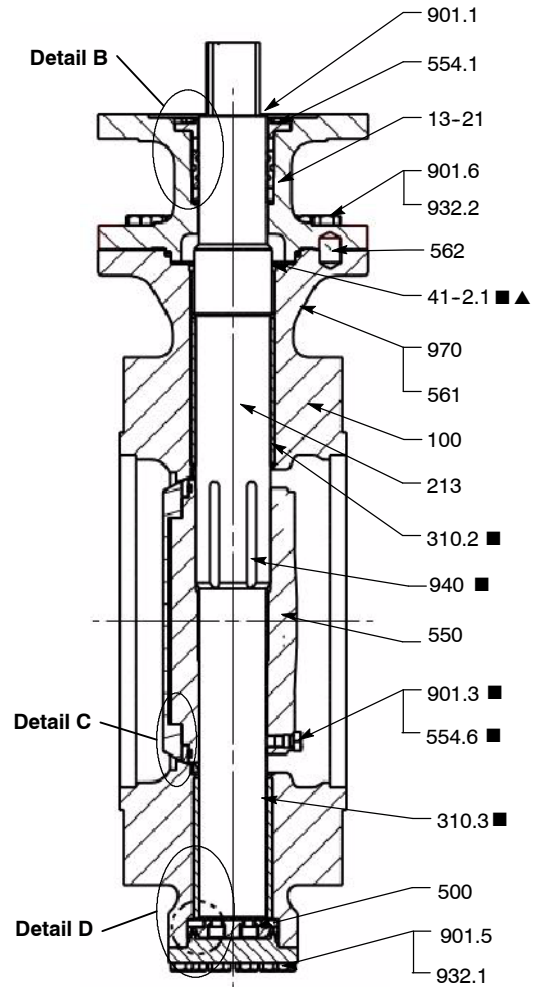

- Spare parts kit for seat
- Spare parts kit for bearing
- ▲ Spare parts kit for shaft sealing

**Parts list for MT version**

Item	Designation	Materials
01-48	Sealing packing	Expanded graphite
100	Body	See page 2
13-21	Extension	See page 2
144	Seat	See page 2
176	Bottom	Stainless steel 316L or A516 gr 70
213	Shaft	See page 2
310.1	Self lubricating strip	Stainless steel + PTFE
310.2	Upper bearing	Stainless steel 316L or Stainless steel + PTFE
310.3	Lower bearing	Stainless steel 316L or Stainless steel + PTFE
400	Static gasket	Stainless steel 316L + graphite or expanded graphite
41-2.1	Extension static joint	Expanded graphite
41-2.2	Bottom static joint	Expanded graphite
412.1	O-Ring	VITON®
412.2	O-Ring	VITON®
412.3	O-Ring	VITON®
500	Anti static device	EN 10213 1.4310
543	Spacer bush	Stainless steel 316L
550	Disc	See page 2
553.1	Upper thrust insert	Stainless steel 316L
553.2	Thrust insert	Stainless steel 316L hard faced
554.1	Upper washer	Stainless steel 316L or EN 10025 S235
554.2	Nord Lock® washer	Stainless steel 316
554.3	Nord Lock® washer	Stainless steel 316
554.4	Spacer	Stainless steel 316L
554.6	Nord Lock® washer	Stainless steel 316L
559	Gasket holder	Stainless steel 316L or EN 10025 S235
561	Grooved nail	EN 10213 1.4303
562	Pin	A638 gr. 660
72-3	Tightening flange	EN 10025 S235 or EN 10088-2 1.4462
81-51	Tightening part	Stainless steel 316L
901.1	Hexagon screw	Steel Cl. 8-8 or Stainless steel A4-70
901.2	Hexagon screw	Steel Cl. 8-8 or Stainless steel A4-80
901.3	Liaison screw	Stainless steel A4-70
901.5	Hexagon screw	Stainless steel A4-70
901.6	Hexagon screw	Stainless steel A4-70
914.2	Hexagon socket head cap screw	Stainless steel A4-70
932.1	Lock washer	Stainless steel 316L
932.2	Lock washer	Stainless steel 316L
940	Cylindrical key	A638 GR 660 (for DN > 10")
970	Identity plate	Stainless steel 316 or equivalent

Construction

TBT version (Type 7 represented)

Disc drive with splines  
DN 8" and DN 10"

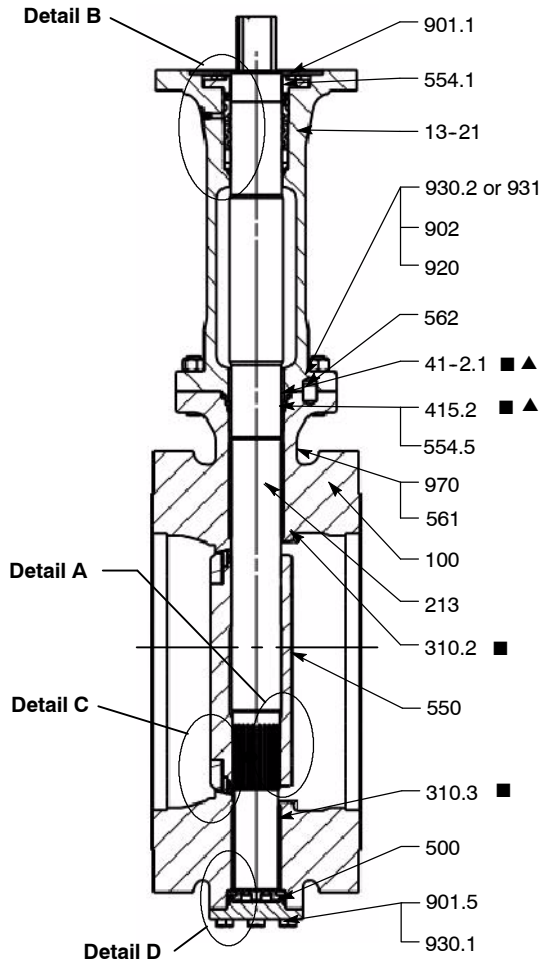

Disc drive with cylindrical keys  
DN 12" to DN 24"

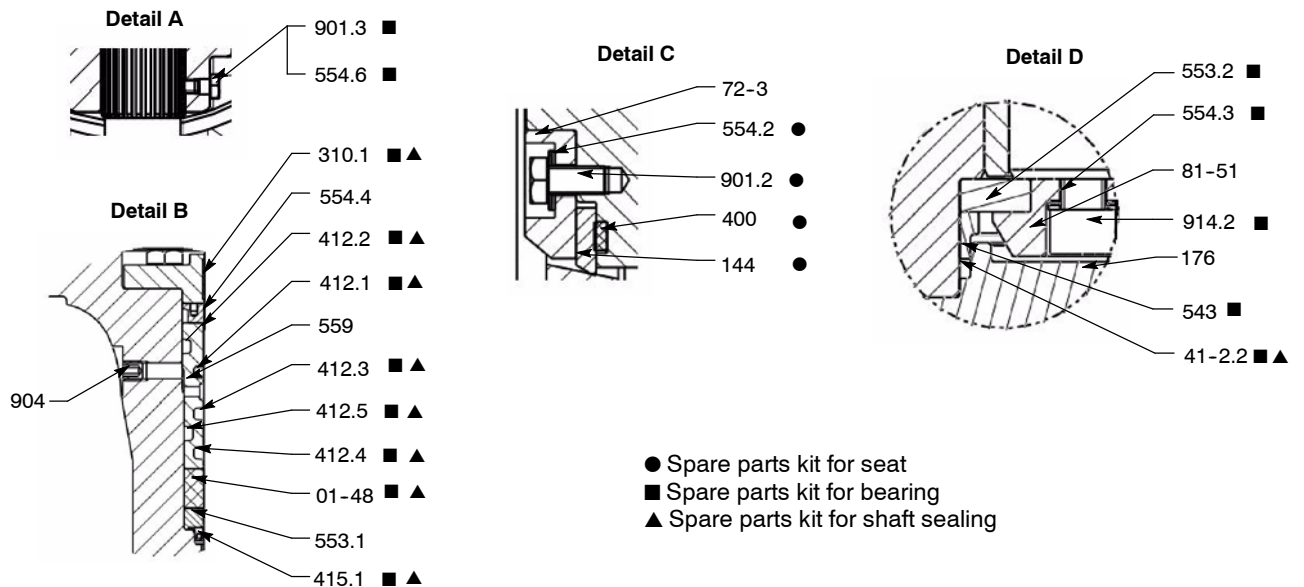
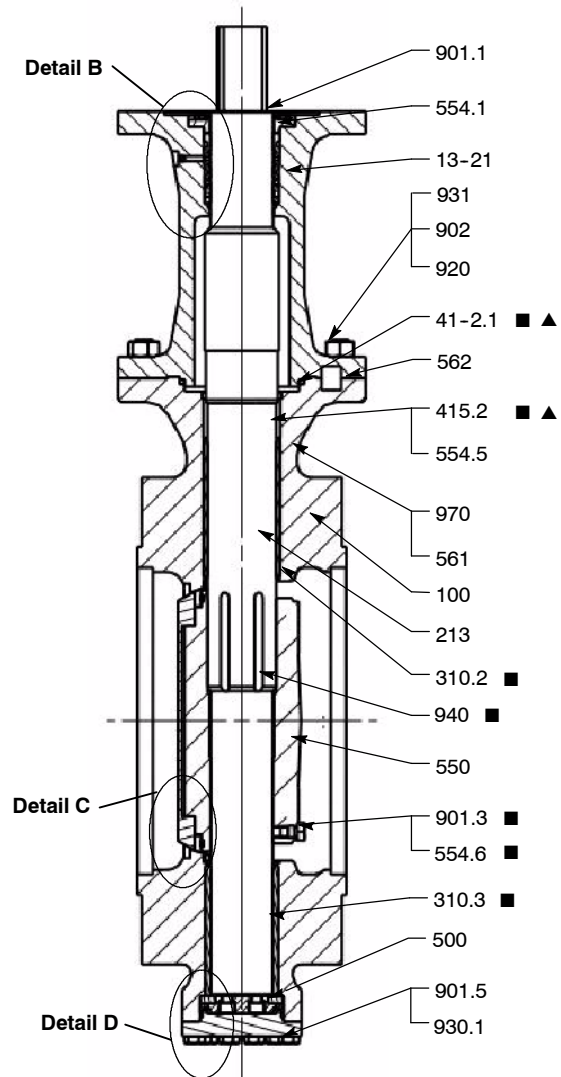

**Parts list for TBT version**

Item	Designation	Materials
01-48	Sealing packing	Expanded graphite
100	Body	See page 2
13-21	Extension	See page 2
144	Seat	See page 2
176	Bottom	Stainless steel 316L
213	Shaft	See page 2
310.1	Self lubricating strip	Stainless steel + PTFE
310.2	Upper bearing	Stainless steel 316L hard faced or Stainless steel + PTFE
310.3	Lower bearing	Stainless steel 316L hard faced or Stainless steel + PTFE
400	Static gasket	Stainless steel 316L + graphite or expanded graphite
41-2.1	Extension static joint	Expanded graphite
41-2.2	Bottom static joint	Expanded graphite
412.1	O-Ring	HC Nitrile(*)
412.2	O-Ring	HC Nitrile(*)
412.3	O-Ring	HC Nitrile(*)
412.4	O-Ring	HC Nitrile(*)
412.5	O-Ring	HC Nitrile(*)
415.1	Lip Seal Ring	PTFE + ELGILOY
415.2	Lip Seal Ring	PTFE + ELGILOY (Option)
500	Anti static device	EN 10213 1.4310
543	Spacer bush	Stainless steel 316L
550	Disc	See page 2
553.1	Upper thrust insert	Stainless steel 316L
553.2	Thrust insert	Stainless steel 316L hard faced
554.1	Upper washer	Stainless steel 316L
554.2	Nord Lock® washer	Stainless steel 316
554.3	Nord Lock® washer	Stainless steel 316
554.4	Spacer	Stainless steel 316L
554.5	Spacer	Stainless steel 316L (Option)
554.6	Nord Lock® washer	Stainless steel 316L
559	Gasket holder	Stainless steel 316L
561	Grooved nail	EN 10213 1.4303
562	Pin	A638 gr. 660
72-3	Tightening flange	Stainless steel 316L or EN 10088-2 1.4462 or A479 gr XM19
81-51	Tightening part	Stainless steel 316L
901.1	Hexagon screw	Stainless steel A4-70
901.2	Hexagon screw	Stainless steel A4-70
901.3	Liaison screw	Stainless steel A4-70
901.5	Hexagon screw	A320 GR. B8M cl.2
902	Stud bolt	A320 GR. B8M cl.2
904	Socket screw	Stainless steel A4-70
914.2	Hexagon socket head cap screw	Stainless steel A4-70
920	Hexagon nut	A 194 GR. 8M
930.1	Lock retainer	Stainless steel 316L
930.2	Nut lock	Stainless steel 316L
931	Lock washer	Stainless steel 316L
940	Cylindrical key	A638 gr 660 (DN > 10")
970	Identity plate	Stainless steel 316 or equivalent

-HC Nitrile: Epichlorohydrin for ambient temperature below minus 25 ° C.



## Dimensions

### Full-lug type body - Type 4 Class 600

#### TBT version

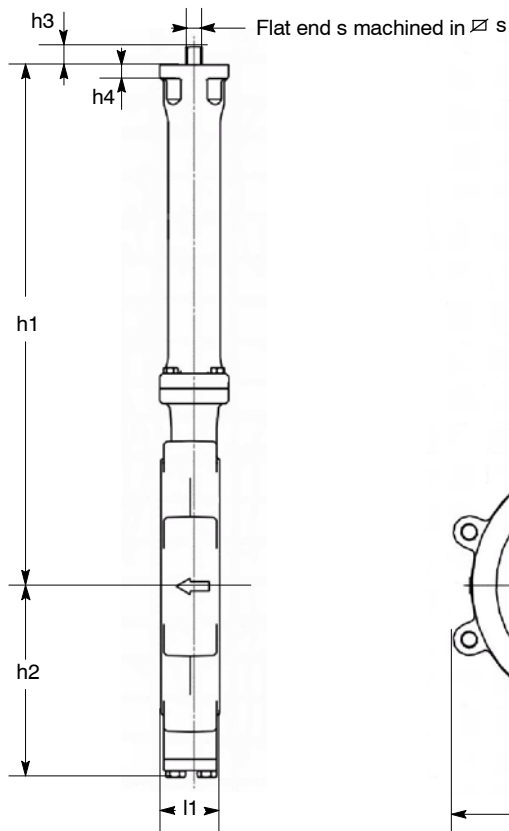

#### MT version

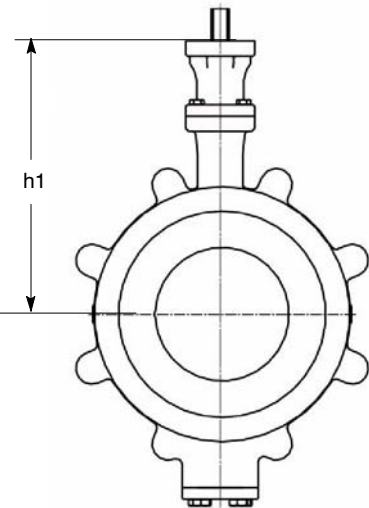

mm

DN*	NPS	d1	l1	TBT		h2	Mounting plate ISO 5211		Square shaft end		Weight Kg	
				MT	h1		n°	h4	45° s	h3	MT	TBT
200	8	390	102	390	690	245	F14	23	36	55	75	95
250	10	490	120	455	760	290	F16	27	50	65	135	155
300	12	540	140	550	770	320	F25	30	60	80	235	260
350	14	580	157	595	895	385	F25	30	60	80	295	325
400	16	665	178	650	925	420	F30	34	70	90	420	470
450	18	720	200	720	995	495	F30	34	70	100	545	585
500	20	790	218	785	1025	540	F35	38	80	110	715	785
600	24	940	235	915	1165	600	F40	45	110	130	1110	1210

For other diameters, please, consult us.

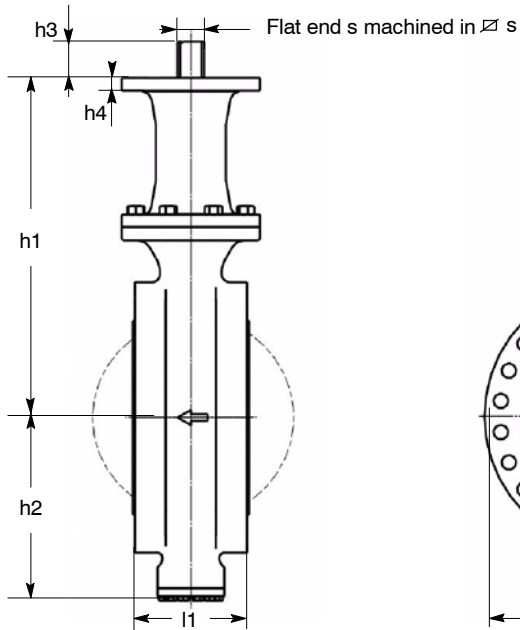
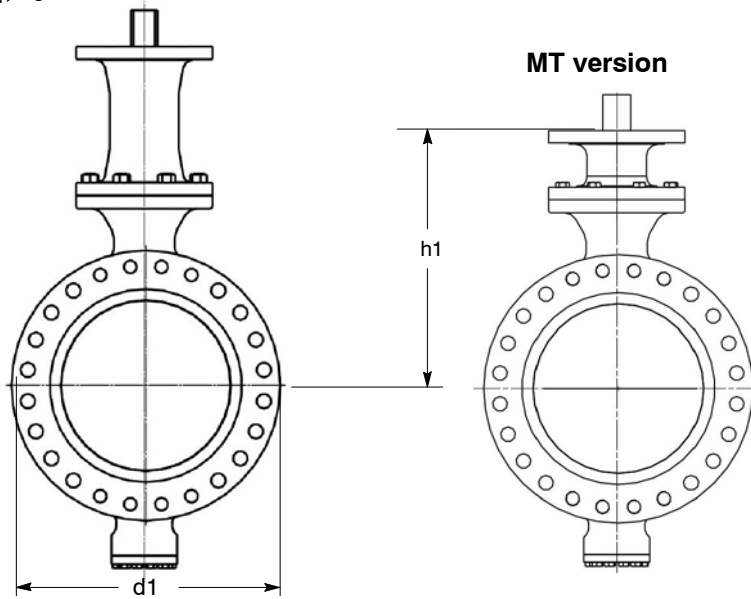
**Dimensions**
**Flanged type body - Type 7 Class 600**
**TBT version**

**MT version**

mm

DN*	NPS	d1	l1	MT		h2	Mounting plate ISO 5211		Square shaft end		Weight kg	
				h1	TBT		n°	h4	∠ s	h3	MT	TBT
200	8	420	230	390	690	245	F14	23	36	55	145	165
250	10	510	250	455	760	290	F16	27	50	65	240	260
300	12	560	270	550	770	320	F25	30	60	80	325	350
350	14	605	290	595	895	385	F25	30	60	80	410	440
400	16	685	310	650	925	420	F30	34	70	90	565	615
450	18	745	330	720	995	495	F30	34	70	100	715	755
500	20	815	350	785	1025	540	F35	38	80	110	935	1005
600	24	940	390	915	1165	600	F40	45	110	130	1330	1430

For other diameters, please, consult us.

## Connections

The valves can be fitted between flanges according to ASME B16.5 Cl. 600 standards (other connections on request).

### Full-Lug and Flanged type body - Type 4 / Type 7 - Class 600

DN	NPS	ASME B16.5 Cl. 600
200	8	✓
250	10	✓
300	12	✓
350	14	✓
400	16	✓
450	18	✓
500	20	✓
600	24	✓

Fitting allowed

## Flange facing

	Raised face RF	Flat face FF
Smooth finish	Standard	On request
Stock finish	On request	On request
RTJ (Type 7 only)	On request	On request

## End of line and downstream dismantling

TRIODIS	Gases or liquids		Liquids*	
	hazardous **	non hazardous **	hazardous **	non hazardous **
class 600	Not permitted	Not permitted	Not permitted	Not permitted

\* Liquids having a vapour pressure at the maximum allowable temperature of not more than 0,5 bar above atmospheric pressure (1013 mbar).

\*\* Fluids hazardous and not hazardous according to PED.

ΔPS Differential pressure

For special applications, please consult us.

**Bolting for full-lug type body - Type 4**

Screw length of the lugs  
**A1 max. = e + X + j**

- e : Flange thickness (customer specification)
- X : Max. implantation of the screw
- j : Thickness of the flange gasket
- B1 : Min. threaded length of the screw  $B1 > A1 - e$

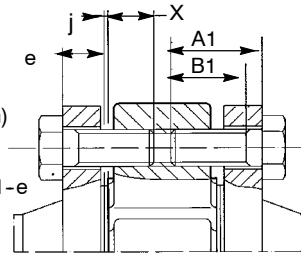

Screw length at shaft passages  
**A2 max. = e + Y + j**

- e : Flange thickness (customer specification)
- Y : Optimal implantation of the screw
- j : Thickness of the flange gasket
- B2 : Min. threaded length of the screw  $B2 > A2 - e$

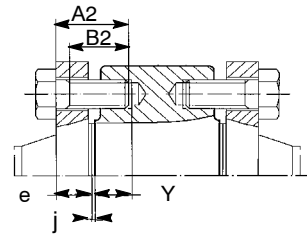

**NB: We do not supply the bolting and flange gasket.**

mm

DN	NPS	ASME B16-5 class 600				
		UN or UNC	Screw A1		Screw A2	
			X	Qty*	Y	Qty*
200	8	1"1/8	47	8	37	4
250	10	1"1/4	56	12	28,5	4
300	12	1"1/4	56	16	32	4
350	14	1"3/8	62	16	32	4
400	16	1"1/2	65	16	40	4
450	18	1"5/8	70	16	41	4
500	20	1"5/8	70	20	42	4
600	24	1"7/8	80	20	40,5	4

\* Quantity of screws by face

### Bolting for flanged type body - Type 7

Screw length on flanges  
**A1 max. = e + j + E1 max. + f**

- E1 : Thickness of valve flange
- e : Flange thickness (customer specification)
- f : Overlength of the screw
- j : Thickness of flange gasket
- B1 : Min. threaded length of the screw  $B1 > A1 - e$

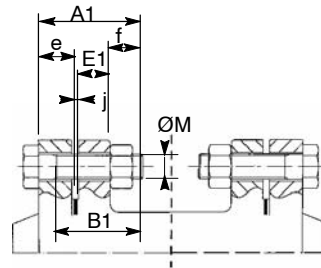

Screw length at shaft passages  
**A2 max. = e + j + Y**

- e : Flange thickness (customer specification)
- Y : Max. implantation of the screw
- j : Thickness of flange gasket
- B2 : Min. threaded length of the screw  $B2 > A2 - e$

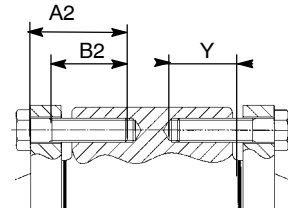

**NB: We do not supply the bolting and flange gasket.**

mm

DN	NPS	E1 max.	ASME B16-5 class 600				
			UN or UNC	Screw A1		Screw A2	
				f	Qty*	Y	Qty*
200	8	66,5	1"1/8	32	8	46	4
250	10	77,5	1"1/4	34	12	51	4
300	12	80	1"1/4	34	16	55	4
350	14	84	1"3/8	38	16	57	4
400	16	90	1"1/2	41	16	57	4
450	18	97,5	1"5/8	48	16	63	4
500	20	102	1"5/8	48	16	69	8
600	24	114	1"7/8	58	16	72	8

\* Quantity of screws by face

Standard variants

Pneumatic actuator ACTAIR / DYNACTAIR

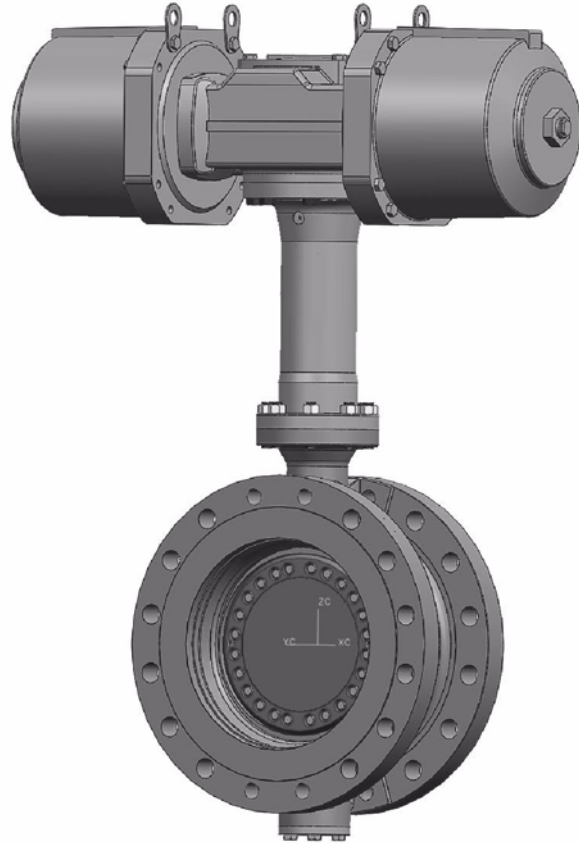

Manual actuator MR



Hydraulic actuator ACTO / DYNACTO

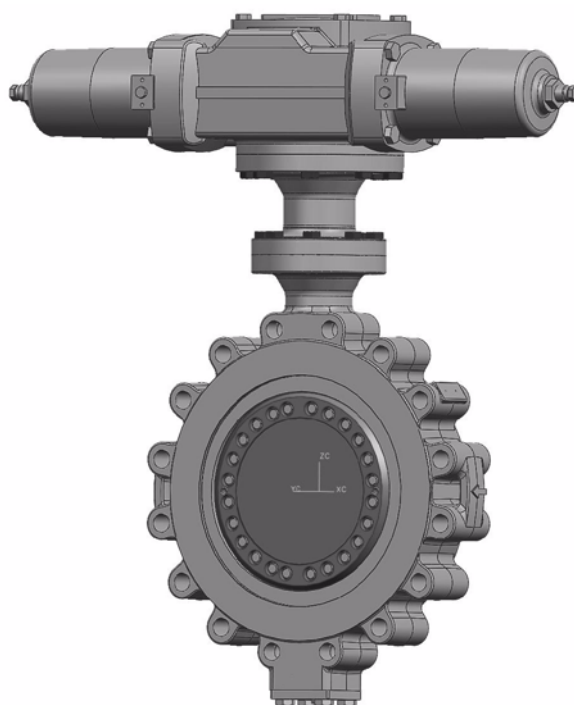





**KSB S.A.S**  
4, allée des Barbanniers • 92635 Gennevilliers Cedex (France)  
Tel. : +33 1 41 47 75 00 • Fax : +33 1 41 47 75 10 • [www.ksb.com](http://www.ksb.com)

