

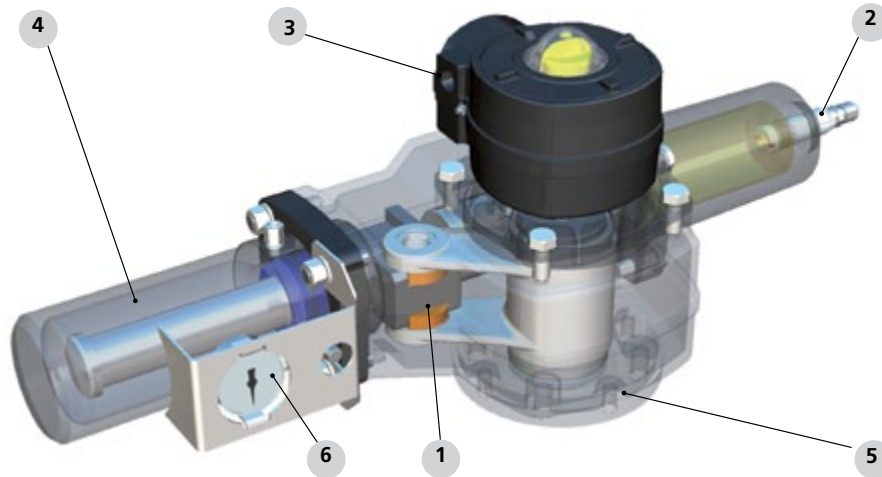

# ENNACTO Single-acting hydraulic actuator with gas cartridge

● For the actuation of any kind of ¼ turn valves



**1 Torque curve kinematics specially adapted for ¼ turn valve**

Patented AMRI yoke kinematics from 2000 Nm which offer an extra additional torque during the stroke to cover potential hydrodynamic torque from the valve

**2 Easy and precise valve position adjustment**

Thanks to the adjustable end stop in the safety position close or open.

**3 Valve monitoring with all AMTROBOX range or any kind of signalization box**

Thanks to VDI/VDE 3845 top plate interface

**4 Compact design single acting actuator**

- Gas cartridge reduce considerably the dimensions compare to spring
- Highly reliable single acting actuator for ESD system

**5 Heavy-Duty actuator for extreme environment**

- Special cast iron bodies for low temperature

**6 Easy maintenance thanks to integrated manometer**

● **Manual emergency control**

- Thanks to hydraulic quick coupling for manual and hand pump

**Technical Data**

Temperature range	Standard version -20 °C à +80 °C Winterized version -50 °C à +80 °C
Control pressure	Up to 160 bar
Output torques	Up to 125000 Nm
Tightness	IP 68
Flange	According to ISO 5211
Top interface	VDI/VDE 3845

**Automation**

- All AMTROBOX limit switch box
- Pressure switch for gas cartridge pressure monitoring



KSB Aktiengesellschaft  
Johann-Klein-Straße 9  
67227 Frankenthal (Germany)  
www.ksb.com