

Applications

- Heating and air-conditioning water,
- Drinking water

Working conditions

- Temperature range,
 - from -10 °C up to +130 °C: E.P.D.M. code XU
 - from -10 °C up to +90 °C: Nitrile code K
- Allowable pressure: max. 16 bar
- Differential pressure Δp :
 - DN 20-200: 16 bar maxi. at room temperature,
 - DN 250-600: 10 bar maxi. at room temperature.
- Vacuum service down to 0,2 absolute bar.
- Maximum fluid velocity under PS: 4m/s for water

Materials

- Refer page 2.

Standard design

- Full-lug type body with raised faces (Type 4).
- Possible downstream pipe dismantling and dead-end service.
- Neck height allowing thermal insulation.
- Thermally insulating device for easier fixation of thermal insulating jacket onto base skirt.
- Elastomer liner: an extra volume of rubber, located at the shaft passage, provides, by compression between the valve body and the disc edge, a perfect leak-tightness at the shaft passages.
- Spherical machined disc ensures perfect upstream/downstream sealing: zero leakage visible to the naked eye.
- Tightness towards the exterior, downstream/upstream tightness and hydraulic testing in accordance with EN 12266-1 leak level A and ISO 5208 category A.

- Face to face dimensions in accordance with ISO 5752 - 20 and EN 558-1-20.
- Mounting plate meeting the following standards: ISO 5211.
- Flange connection standard DIN/ISO PN 10 and 16.
- This valve cannot be dismantled.
- Marking in accordance EN 19.
- Contains no asbestos, CFC, superchlorinated biphenylene, substances impairing paint wetting.
- Polyurethane paint, 80 μm thickness, colour orange ref. RAL 2002.
- The valves meet the safety requirements of the pressure Equipments Directive 97/23/EC (PED) appendix 1 for liquids of the group 1 and fluids of the group 2.

Standard variant

- BOAXMAT-SF valves with electrical actuators ACTELEC.
- Washed and packed valves without substances impairing paint wetting.
- Pneumatic actuator ACTAIR / DYNACTAIR
- Electric actuator ACTELEC
- Position detection AMTROBOX
- Pneumatic distribution for On-Off function AMTRONIC
- Positioner SMARTRONIC

Remark

- Operating instructions 8417.8/.-90

Data to be supplied when ordering

- BOAX-SF valves in accordance with type series booklet 8415.12/15-EN
- Size,
- Working conditions: nature of fluid, pressure, temperature.
- Actuation.



Materials

Body	KSB code
Type 4: Spheroidal graphite cast iron JS 1030	3g
Driving shaft / Shaft	KSB code
Stainless steel 1.4029 (13 % Cr)	6k
Disc	KSB code
Stainless steel 1.4301 / 1.4308 (18-10 type)	6g
AMRING® liner	KSB code
E.P.D.M	XU
High content nitrile	K

Construction

DN 20 and 25

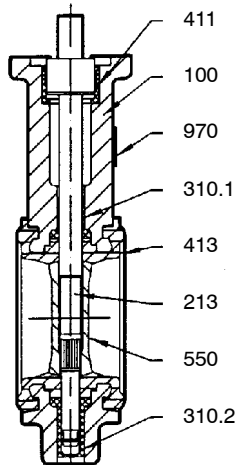

DN32

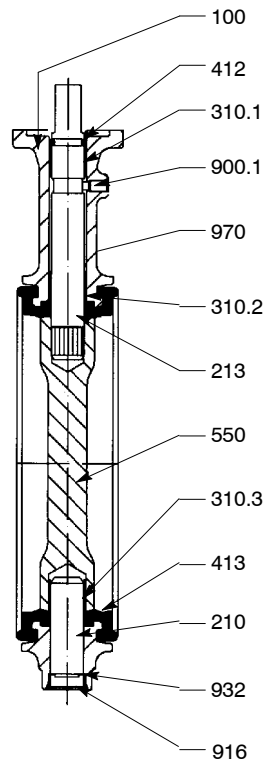

DN 40 to 150

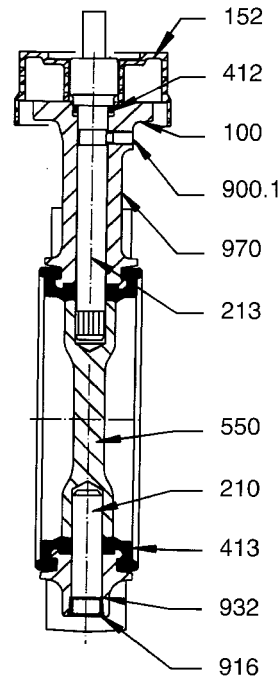

DN 200

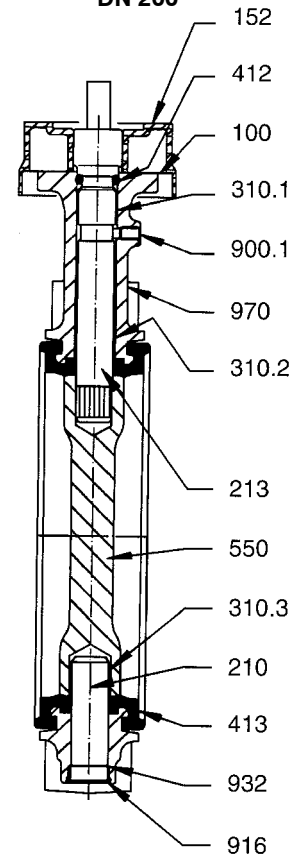

Item	Designation	DN	Materials
100	Body	20 to 200	JS 1030 ductile iron
152	Thermal isolating device	40 to 200	Polyamid fiber glass filled
210	Shaft	32 to 200	13% Chromium stainless steel (1.4029)
213	Driving shaft	20 to 200	13% Chromium stainless steel (1.4029)
310.1	Plain bearing	20, 25, 32 and 200	PTFE filled on steel casing
310.2	Plain bearing	20, 25, 32 and 200	PTFE filled on steel casing
310.3	Plain bearing	32 and 200	PTFE filled on steel casing
411	Gasket	20	Acetal
412	O-Ring	32 to 200	E.P.D.M.
413	Liner	20 to 200	E.P.D.M. code XU or Nitrile code K
550	Disc	20 to 200	Stainless steel 1.4301 / 1.4308 (18-10 type)
900.1	Screw	32 to 200	Stainless steel
916	Plug	32 to 200	Polyamid
932	Self-locking	32 to 200	Steel
970	Identity plate	20 to 200	Adhesive polyester coated

Construction

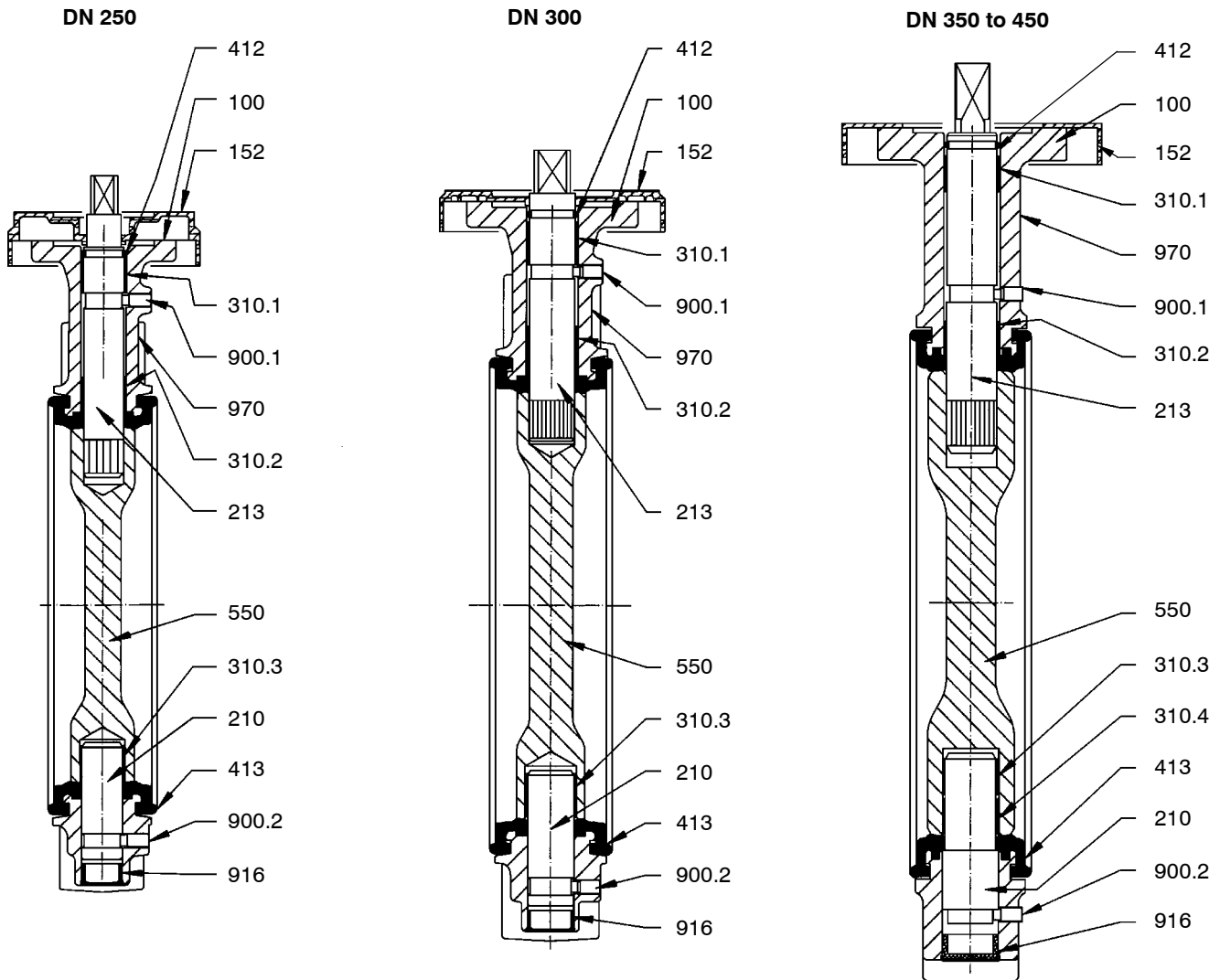

Item	Designation	DN	Materials
100	Body	250 to 450	JS 1030 ductile iron
152	Thermal isolating device	250 to 450	polyamid fiber glass steel
210	Shaft	250 to 450	13% chromium stainless steel (1.4029)
213	Driving shaft	250 to 450	13% chromium stainless steel (1.4029)
310.1	Plain bearing	250 to 450	PTFE filled on steel casing
310.2	Plain bearing	250 to 450	PTFE filled on steel casing
310.3	Plain bearing	250 to 450	PTFE filled on steel casing
310.4	Plain bearing	350 to 450	PTFE filled on steel casing
412	O-Ring	250 to 450	E.P.D.M.
413	Liner	250 to 450	E.P.D.M. code XU or Nitrile code K
550	Disc	250 to 450	Stainless steel 1.4301 / 1.4308 (18-10 type)
900.1	Screw	250 to 450	Stainless steel
900.2	Screw	250 to 450	Stainless steel
916	Plug	250 to 450	Polyamid
970	Identity plate	250 to 450	Adhesive polyester coated

Construction

DN 500 and 600

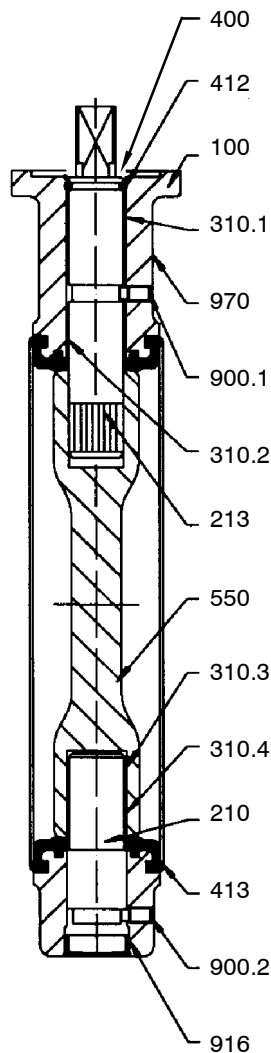

Item	Designation	DN	Materials
100	Body	500 and 600	Spheroidal graphite cast iron JS 1030
210	Shaft	500 and 600	13% chromium stainless steel (1.4029)
213	Driving shaft	500 and 600	13% chromium stainless steel (1.4029)
310.1	Plain bearing	500 and 600	PTFE filled on steel casing
310.2	Plain bearing	500 and 600	PTFE filled on steel casing
310.3	Plain bearing	500 and 600	PTFE filled on steel casing
310.4	Plain bearing	500 and 600	PTFE filled on steel casing
400	Flat gasket	500 and 600	Polypropylene
412	O-Ring	500 and 600	E.P.D.M.
413	Liner	500 and 600	E.P.D.M. code XU or Nitrile code K
550	Disc	500 and 600	Stainless steel 1.4301 / 1.4308 (18-10 type)
900.1	Screw	500 and 600	Stainless steel
900.2	Screw	500 and 600	Stainless steel
916	Plug	500 and 600	Polyethylene
970	Identification plate	500 and 600	Adhesive polyester coated

Valve without actuator

Overall dimensions (mm) and weights (kg)

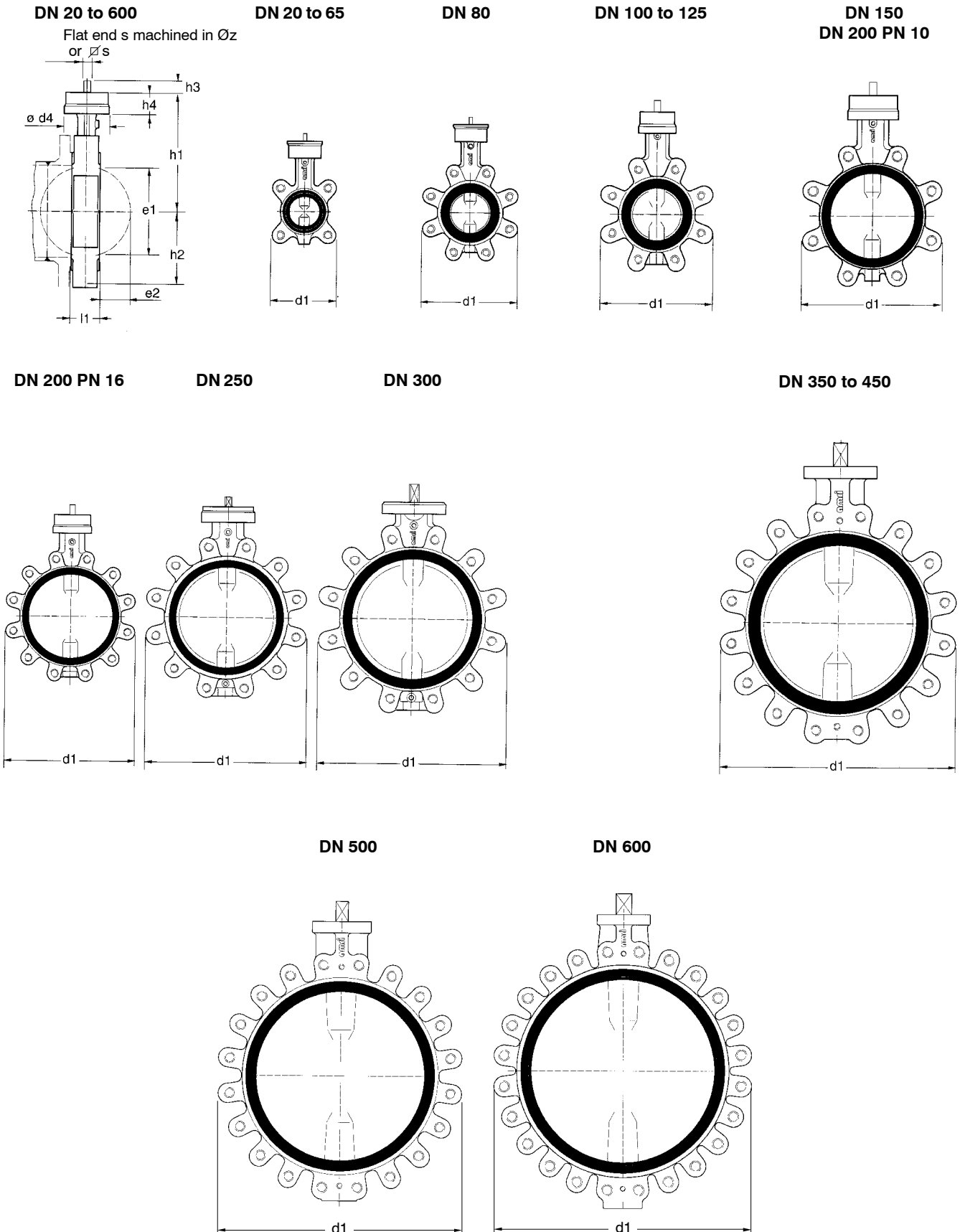

Valve without actuator
Overall dimensions (mm) and weights (kg)

DN	Face to face l1					Mounting plate ISO 5211		Flat shaft end			Square shaft end		Disc clearance		Weight kg
						N°	h4	s	øz	h3	□ s	h3	e1	e2	
20	27	88	-	104	41	F04	29	9	12	14			15	4	1,0
25	27	88	-	104	41								15	4	1,0
32	33	108	-	126	54								32	4	2,0
40	33	108	60	126	54								32	4	2,0
50	43	120	60	131	60								33	4	2,5
65	46	134	60	157	67								55	11	3,0
80	46	178	60	163	89								71	17	4,5
100	52	210	70	191	105								F05	38	11
125	56	236	70	205	118	11	14	24	119	35					9,0
150	56	260	95	224	130	F07	42	17	22	25			144	46	11,0
200 ⁽¹⁾	60	312	95	252	156			17	22	25	196	69	24,0		
200 ⁽²⁾	60	322	95	252	161			17	22	25	196	69	25,0		
250	68	396	133	275	198	F10	38				19	25	249	92	39
300	78	466	158	289,5	233	F12	28,5				22	29	297	111	46
350	78	530	183	338	265	F12					25	45	326	127	70
400	102	598	183	383	296	F14	29				36	50	370	140	101
450	114	656	183	410	329	F14					36	55	422	160	160
500	127	708	-	440	359	F14	27				36	55	470	178	179
600	154	822	-	495	439	F16	27				50	65	566	215	256

(1) Direct connection with flange PN10 (8 holes)

(2) Direct connection with flange PN16 (12 holes)

Valve with manual actuation

Overall dimensions (mm) and weight (kg)

LP ¼ turn handle operation - DN 20 to 250

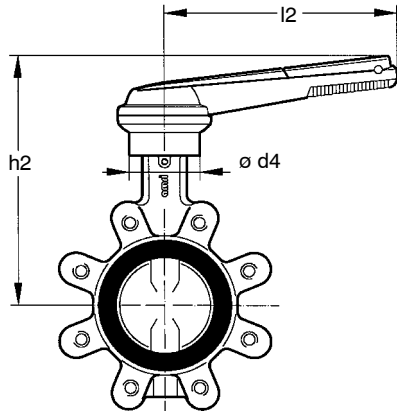

DN	LP ¼ turn handle operation			
	l2	h2	d4	Weight*
20	LP 165	156	60	1,2
25		156		1,2
32		178		2,5
40		178		2,5
50		183		3,0
65		209		3,5
80	215	5,0		
100	LP 230	253	70	6,2
125		266		9,7
150	LP 330	298	95	12,0
200		326		26,2
250	LP 460	460	133	41,2

Manual actuator operation MA - DN 20 to 250

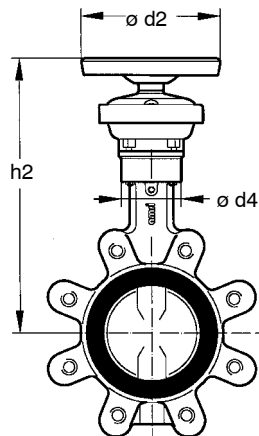

* The indicated weights are those of the valve + the handle

DN	Manual actuator operation				
	Type	d2	h2	d4	Weight*
20	MA 12	140	203	60	3,5
25			203	60	3,5
32			199	60	3,5
40			220	60	3,5
50			225	60	4,0
65			251	60	4,5
80			257	60	6,0
100			285	70	7,0
125			299	70	10,5
150			MA 25	225	355
200	383	95			28,0
250	406	133			42,0

Manual actuator operation MN and MR - DN 300 to 600

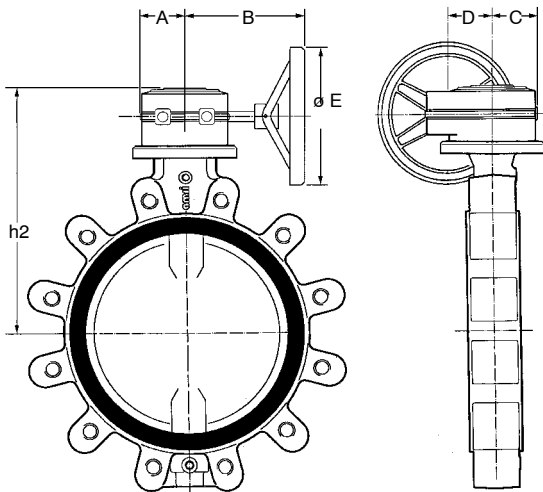

* The indicated weights are those of the valve + the actuator

DN	Manual actuator operation							
	Type	A	B	C	D	ØE	h2	Weight*
300	MN 40	70	230	60	60	200	434	49,4
350	MN 80	90	230	70	75	250	490	74,6
400	MR100	86	233	88	88	350	595	114,6
450							625	152,6
500							677	194,0
600	MR200	120	270	108	117	350	743	280,0

* The indicated weights are those of the valve + the actuator

On request

Valve with manual actuation

Overall dimensions (mm) and weight (kg)

LP ¼ turn handle operation - DN 20 to 250

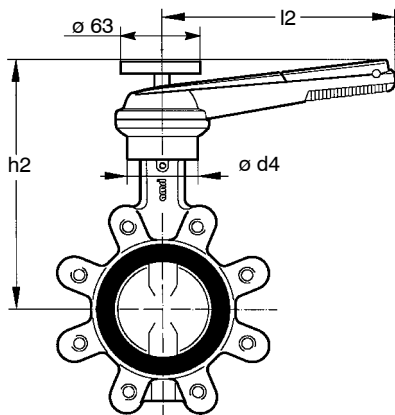

BOAX®-SF THERMAX:

Variant with thermometer

The thermometer mounted on the BOAX®-SF valve with handle can measure the values between 0° C and + 120° C for an heating installation and between - 20° C and + 60° C for a cooling installation.

For DN 20 to 250, precision class = 1.

LP ¼ turn handle operation				
DN	l2	h2	d4	Weight*
20	165	153	60	1,2
25		156		1,2
32		160		2,5
40		178		2,5
50		183		3,0
65		209		3,5
80	230	215	70	5,0
100		253		6,2
125		266		9,7
150	330	298	95	12,0
200		326		26,2
250	460	460	133	41,2

* The indicated weights are those of the valve + the handle

BOAXMAT-SF - Valve with electric actuation
Actuator selection: lubricated medium

DN	Single phase A. C. 230 V, 50 Hz			
	ACTELEC type	Standard operating time	ACTELEC type	Standard operating time
20	LEA-2	20 s	OA 3	11 s
25				
32				
40				
50	LEA-3	20 s	OA 6	6 s
65	LEB-4	6 s		
80	LEB-10	35 s 6 s *		
100			OA 15	15 s *
125			ASP	10 s *
150				
200				
250				
300			AS 50	30 s *
350				
400				
450	BS 100	60 s *		
500				

*For other operating time, please consult us.

3-phase A. C. 400 V, 50 Hz		
DN	ACTELEC	Standard operating time
20	OA 6	6 s
25		
32		
40		
50		
65		
80		
100	OA 8	6 s *
125		
150	OA 15	15 s *
200	ASP	10 s *
250		
300		
350	AS 50	30 s *
400		
450	BS 100	60 s *
500		

*For other operating time, please consult us

Main electrical equipments

ACTELEC	LEA-2	LEA-3	LEB-4	LEB-10	OA 3	OA 6	OA 8	OA 15	ASP	AS 50	BS 100	
Opening and closing limit switches	Standard											
Adjustable extreme position mechanical stops	Standard											
Opening and closing torque limit switches	Standard								Standard			
Protection by thermic switch			Standard									
Manual override	Standard											
Visual position indicator	Standard											
Heating resistance	Integrated		To be cable									

Electrical characteristics (for standard operating time)

ACTELEC type	Single phase A. C. 230 V, 50 Hz										
	LEA-2	LEA-3	LEB-4	LEB-10	OA 3	OA 6	OA 8	OA 15	ASP	AS 50	BS 100
Nominal intensity (A)	0,1	0,14	0,8	0,5	0,7	0,6	1,2	0,6	1,8	1,2	1,2
Starting intensity (A)	0,24	0,3	0,9	0,6	0,9	0,9	1,7	0,9	2,5	1,7	1,7
Power (W)	35,0	45,0	30,0	15,0	27,0	30,0	60,0	30,0	100,0	60,0	60,0

ACTELEC type	3-phase A. C. 400 V, 50 Hz					
	OA 6	OA 8	OA 15	ASP	AS 50	BS 100
Nominal intensity (A)	0,3	0,6	0,3	0,8	0,3	0,6
Starting intensity (A)	0,5	1,1	0,5	1,6	0,8	1,1
Power (W)	30	100	30	150	60	100

Electric actuators OA, AS and BS: all markets (Type Series Booklet 8521.12/-10)

- Rated current:
 - single phase 230 V, 50 Hz : all types
 - 3-phase 230 V or 400 V, 50 Hz: all types except OA 3
- Intermittent duty: S4-30 %
- Protection degree: IP 67
- Working temperature: from - 20 °C to + 70 °C
- On request: (Please consult us):
 - Explosion-proof protection,
 - Contacts supplémentaires réglables
 - Electrical motor with built-in thermal protection and epoxy paint finish,
 - Regulation function for OA8, AS25 and AS 50,
 - Feed-back position,
 - Potentiometer
 - Control boxes,
 - Other voltages.

Electric actuators LEA and LEB: Only building market (Type Series Booklet 8521.16/-10)

- Rated current:
 - single phase 230 V, 50 Hz-60 Hz : all types
- Intermittent duty: S4-30 %
- Protection degree: IP 65

BOAXMAT-SF - Valve with electric actuation

Overall dimensions (mm) weight (kg)

LEA-2 and LEA-3

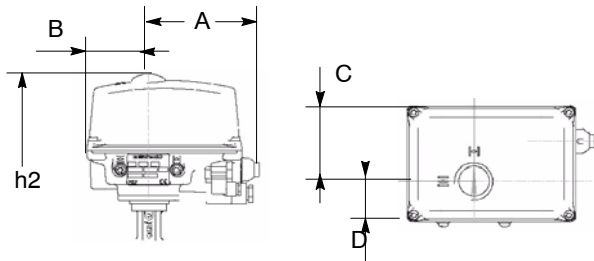

LEB-4 and LEB-10

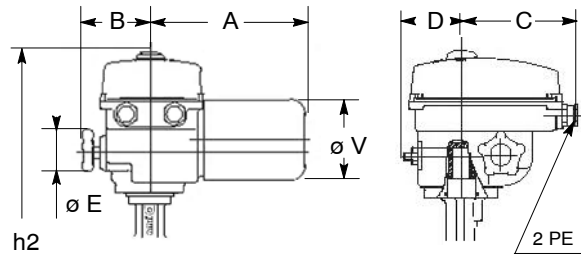

OA3

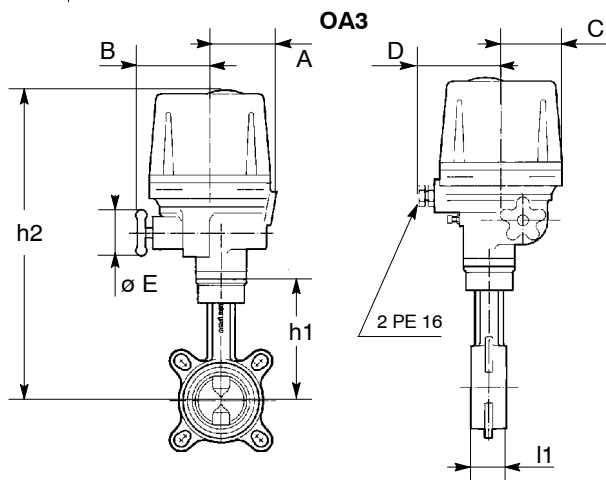

OA6, OA8 and OA15

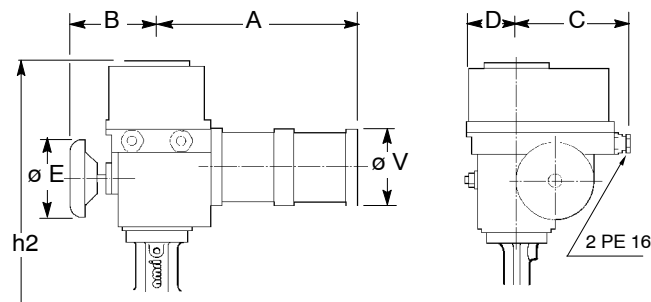

ASP, AS50 and BS100

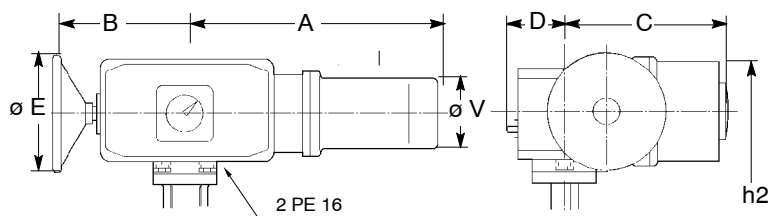

BOAXMAT-SF - Valve with electric actuation
Overall dimensions (mm) weight (kg)

DN	ACTELEC	l1	h1	h2	b1	b2	d2	d3	l2	l3	Weight* kg
20	LEA-2	27	104	244	118	65	77	41	-	-	3,6
25		27	104	244							3,6
32		33	126	261							3,6
40		33	126	261							3,6
50	LEA 3	43	131	266	118	65	77	41	-	-	4,1
65	LEB 4	46	157	341	148	90	140	65	60	106	8,0
80	LEB 10	46	163	347	191	90	140	65	60	106	10,0
100		52	191	375							11,0
125		56	205	389							14,5
20	OA 3	33	109	343	59	134	-	60	90	93	5,0
25		33	109	343							5,0
32		33	105	321							5,0
40		33	126	371							7,0
50		43	131	376							7,5
65		46	157	402							8,0
40	OA 6	33	126	342	200	90	106	60	145	65	7,7
50		43	131	347							8,2
65		46	157	373							8,7
80		46	163	379							10,2
100		52	191	407							11,2
125	OA 8	56	205	421	200	90	106	60	145	65	15,8
150	OA 15	56	224	439	260	112	106	60	145	65	18,5
200	ASP	60	252	429	312	187	139	165	226	89	43,0
250		68	275	452							57,0
300	AS 50	78	289,5	466,5	340	187	139	250	226	89	64,0
350		78	338	515							88,0
400	BS 100	102	383	550	392	187	139	250	284	134	127,0
450		114	410	577							165,0
500		127	440	607							205,0

* The indicated weights are those of the valve + the actuator

Installation instructions:

The BOAXMAT-SF are factory preset and tested, do not modify them.

Prior to any actuation, position the valve at mid course, check its rotation direction and check the stroke limiting stops for correct operation.

The BERNARD service leaflets as well as the electrical wiring diagrams are supplied.

Integral protection of the motor is ensured when the thermal switch included in the winding is properly connected.

The actuators are disabled by the stroke limiting stops.

The torques limiters on versions AS and BS are safety contacts.

In case of disturbance, they stop the motor via the control box and the same time display the problem.

The torques limiters are contacts with a limited usable life.

Dimensions a and sizes of flange coupling screws in case of bolted assembly

DN	Flanges according to			
	EN 1092 (PN 10) Type 11		EN 1092 (PN 16) Type 11	
	a	Screw size	a	Screw size
20	51,5	8 x M12 x 30	51,5	8 x M12 x 30
25	46,5	8 x M12 x 30	46,5	8 x M12 x 30
32	38,0	8 x M16 x 30	38,0	8 x M16 x 30
40	51,0	8 x M16 x 30	51,0	8 x M16 x 30
50	48,0	8 x M16 x 35	48,0	8 x M16 x 35
65	64,5	8 x M16 x 35	64,5	8 x M16 x 35
80	63,0	16 x M16 x 40	63,0	16 x M16 x 40
100	81,0	16 x M16 x 40	81,0	16 x M16 x 40
125	79,5	16 x M16 x 40	79,5	16 x M16 x 40
150	81,5	16 x M20 x 45	81,5	16 x M20 x 45
200	82,0	16 x M20 x 50	82,0	24 x M20 x 50
250	77,5	24 x M20 x 50	72,5	24 x M24 x 50
300	67,0	24 x M20 x 50	59,5	24 x M24 x 50
350	90,0	32 x M20 x 55	82,5	32 x M24 x 60
400	100,5	32 x M24 x 60	93,0	32 x M27 x 70
450	105,5	40 x M24 x 60	93,0	40 x M27 x 70
500	108,0	40 x M24 x 60	85,5	40 x M30 x 80
600	107,0	40 x M27 x 70	77,0	40 x M33 x 90

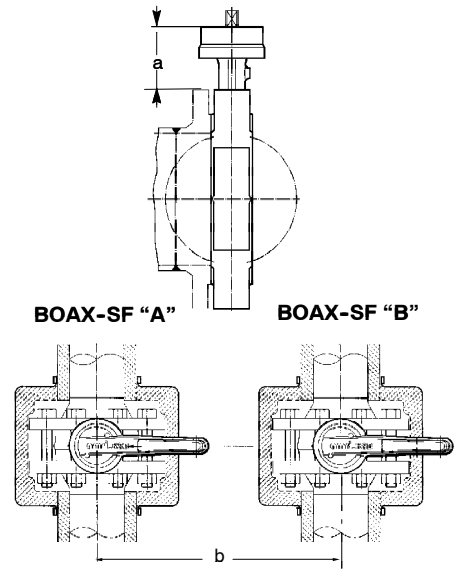

If threaded rods or studs are used, add at least one nut length to the above-mentioned screw lengths.

Minimum deviations on distributor

The minimum deviations between the distribution loops are defined by the requirements applicable to heating installations, regardless of the control handles or reduction gears used.

DN	Minimum deviations b (mm)																	
	BOAX-SF "A"																	
	20	25	32	40	50	65	80	100	125	150	200	250	300	350	400	450	500	600
20	240	240	245	265	270	295	300	310	325	340	370	405	430	484	530	570	610	670
25		245	250	265	270	295	305	310	325	340	370	410	430	487	532	572	612	672
32			255	270	275	300	305	315	330	345	370	415	435	491	536	576	618	678
40				290	295	320	325	335	345	365	390	430	455	510	554	594	635	695
50					300	325	330	340	350	370	400	435	460	514	560	600	640	700
65						350	355	365	380	395	425	460	485	540	585	625	665	725
80							365	370	385	400	430	470	490	546	591	631	673	733
100								380	395	410	440	475	500	554	600	640	680	740
125									410	425	450	490	515	570	614	654	695	755
150										440	470	510	530	585	630	670	710	770
200											500	540	560	619	658	700	740	800
250												575	600	651	696	736	778	838
300													620	675	720	760	800	860
350														730	775	815	855	915
400															820	860	900	960
450																900	940	1000
500																	980	1040
600																		1100

Product features - to our customers' benefit

Thermal isolating device

- Quick and easy installation of thermal insulating jacket.
- No thermal loss.
- No condensation water.

BOAX-SF
DN 150

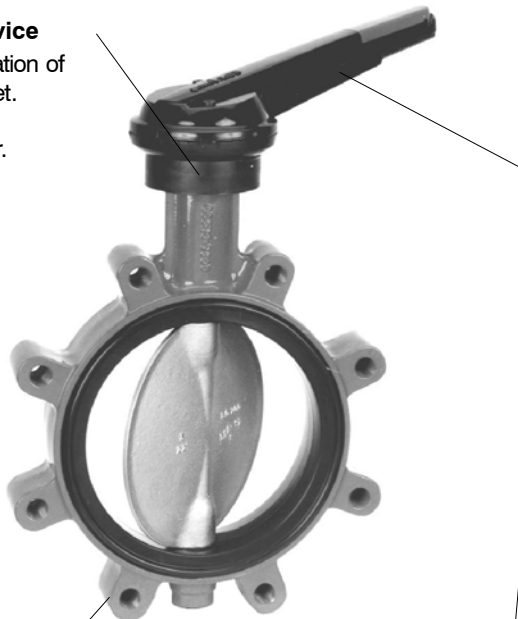

Padlockable and/or lead sealable control handle (DN 20-250)

- Safety against unauthorized operation

Reducer

- Possibility of mounting in the open air owing to its protection class IP 67.
- Small size, hence reduced overall dimensions.

Full-lug type body with raised faces

- Possibility of end of line and downstream dismantling.
- Small overall dimensions.
- Possibility of mounting between flanges PN 10/16.
- Possibility of thermal insulation in accordance with the requirements applicable to heating installations.

Disc with spherical machining

- Ensures permanent tightness at shaft passage way.

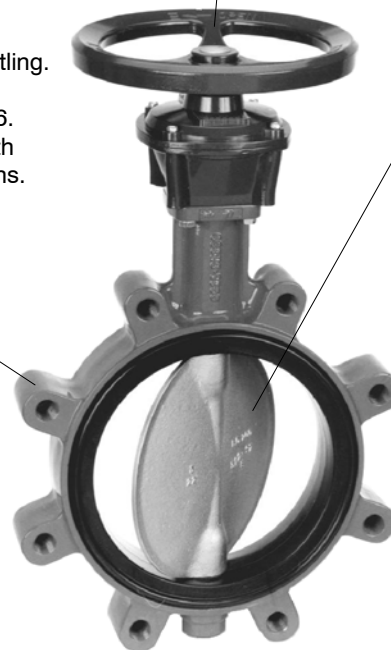

BOAX-SF
DN 150

This leaflet is not contractual and may be amended without notice

28.11.12

8415.12/15-EN