

Limit switch box for pneumatic actuators ACTAIR and DYNACTAIR, and manual actuators MR

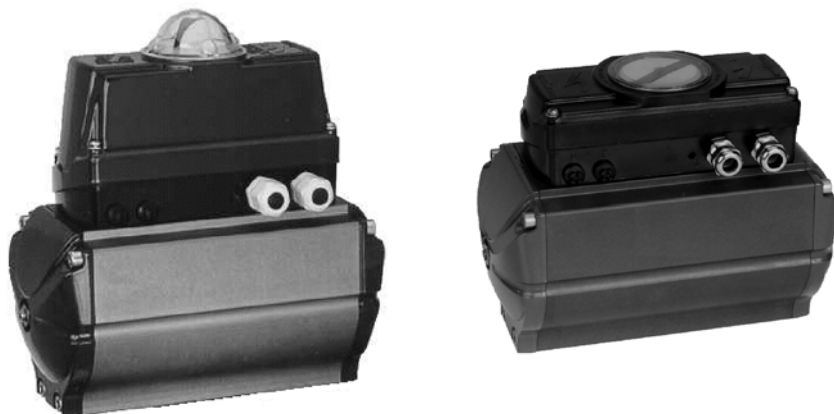

On/Off position detection

Applications

- All sectors of Water, Energy and Industry markets.

General information

- AMTROBOX is specially designed for the ACTAIR series of double acting pneumatic actuators and DYNACTAIR series of spring return pneumatic actuators, and the manual reducers MR.
- This box integrates the On/Off position detection function:
 - by microswitches (IP 67 and gold plated) in standard, others references are available.
 - by inductive proximity detectors.
- Its adjustable cams device for position detection makes it very reliable and easy to adjust.
- The electrical connections are made by packing-gland or debrochable connector.

Protection

- IP 67 with output by packing-gland
- IP 65 with output by connector 12 broches

Temperature range

- From -20° up to +80° C

Materials

- Its cataphoresis coating ensures a good resistance in corrosive environments.
- Cover and base plate: aluminium

Standard variants

- Low cover version: R 1149 and RA 1149
- High cover version: R 1140, RA 1140, R1141 and RA 1141.
- ATEX version low cover dust explosive atmosphere 22 : X 1149 and XA 1149,
- ATEX version high cover dust explosive atmosphere 22: X 1140, XA1140, X 1141 and XA 1141.

Options

- Angle sensor
- Feed-back position
- Heating resistance
- 12-pin connector
- Fieldbus

This leaflet is also to be used as a start-up guide ref. 42 057 239

High cover version
AMTROBOX R 1140, RA 1140, R 1141 and RA 1141

Low cover version
AMTROBOX R 1149 and RA 1149

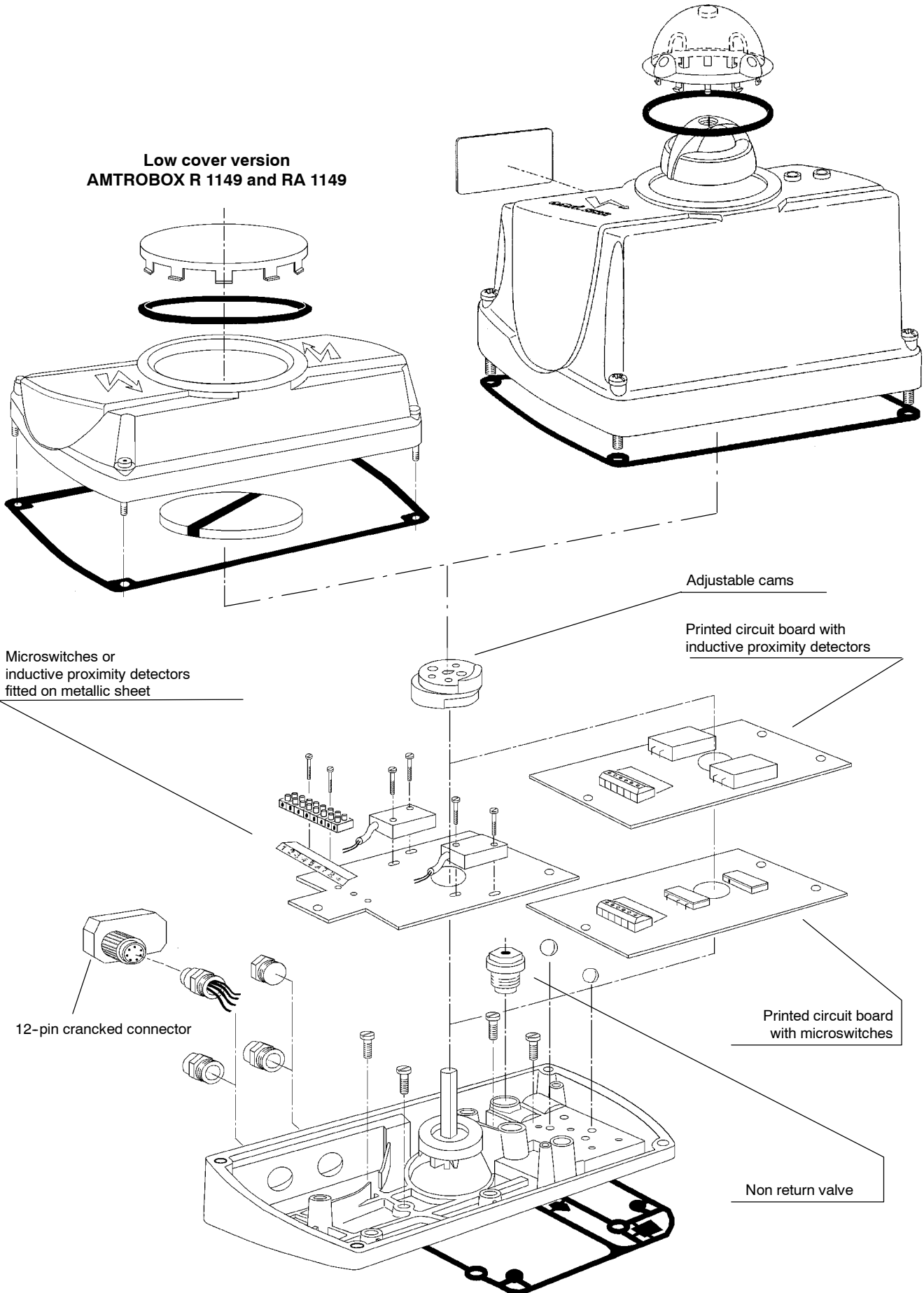

Contents

	Page
General technical data	
- Common parts	4
- General technical characteristics, overall dimensions	5
Position detection by microswitches on printed circuit board AMTROBOX R 1140 and R 1149	
- Description	6
- Technical characteristics of microswitches, wiring diagram, adjustment of cams	7
Position detection by inductive proximity detectors on printed circuit board AMTROBOX R 1141 and R 1149	
- Description	8
- Technical characteristics of proximity detectors, wiring diagram, adjustment of cams	9
Position detection by special microswitches or proximity detectors fitted on metallic plate AMTROBOX RA 1140, RA 1141 and RA 1149	
- Description	10
Options	
- Angle sensor - AMTROBOX R 1140, RA 1140, R 1141 and RA 1141	11
- 4-20 mA feed-back position - AMTROBOX R 1140 and R 1141	11
- Heating resistance - AMTROBOX R 1140, RA 1140, R1141, RA 1141, R 1149 and RA 1149	12
- 12-pin connectors - AMTROBOX R 1140, RA 1140, R1141, RA 1141, R 1149 and RA 1149	12
- Fieldbus - AMTROBOX R 1140 and R 1141	12

Common parts

Low cover version
AMTRONIC R 1149 and RA 1149

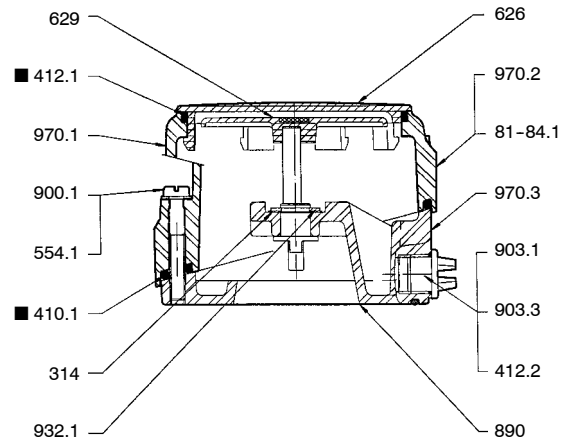
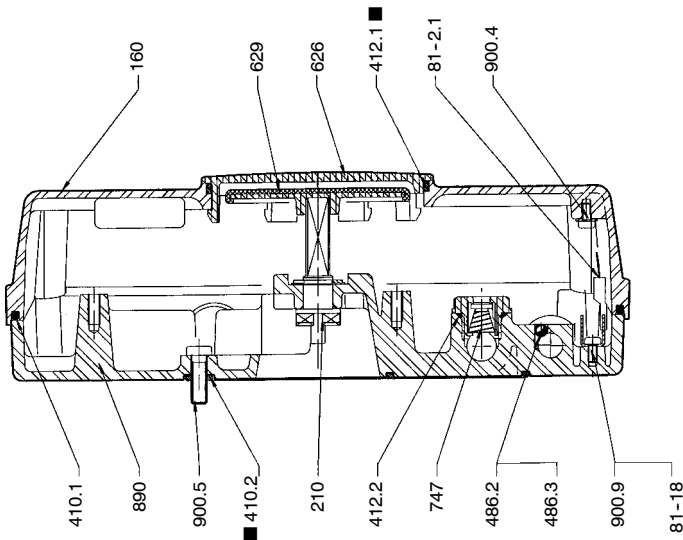

High cover version
AMTRONIC R 1140, RA 1140, R1141 and RA 1141

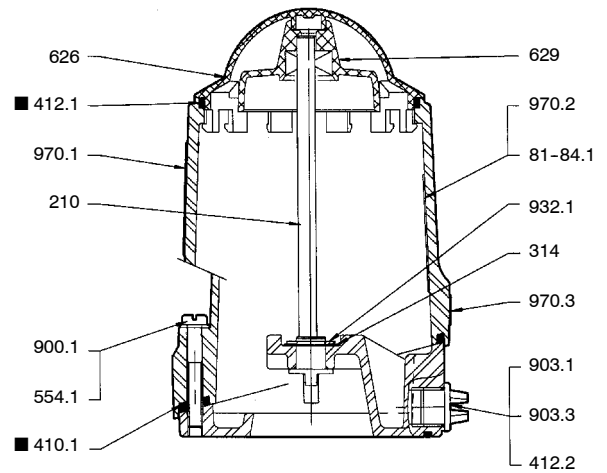
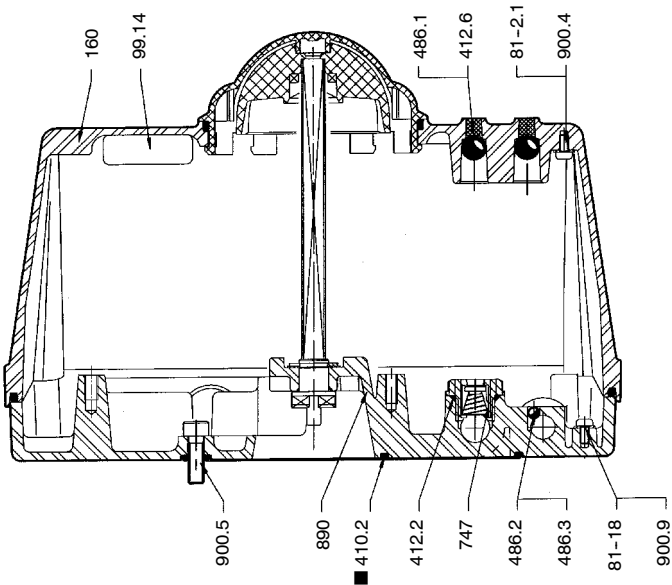

■ Parts included in the spare parts kit

Common parts

Item	Designation	Materials
160	Cover	Light alloy with cataphoresis coating
210	Shaft	Acetal + 30% fibreglass
314	Thrust washer	304 type stainless steel
410.1	■ Cover gasket	Nitrile
410.2	■ Base plate cover	Nitrile
412.1	■ O-Ring	Nitrile
412.2	O-Ring	Nitrile
412.6	Rope (High cover version)	Nitrile
486.1	Ball (High cover version)	Stainless steel
486.2	Ball	Steel
486.3	Ball	Steel
554.1	Plain washer	A2-70 stainless steel
626	Sight glass	Transparent polycarbonate
629	Pointer	Polyamide
747	Non return valve sub-assembly	-----
81-18	Faston snap	-----
81-2.1	Ground wire	Copper
81-84.1	Wiring diagram	-----
890	Base	Light alloy with cataphoresis coating
900.1	Cheese-head screw	A2-70 stainless steel
900.4	Sel-cutting screw	Zinc coated steel cl.8-8
900.5	Cheese-head screw	Stainless steel
900.9	Pozidriv screw	Zinc coated steel cl.8-8
903.1	1/4" Gas threaded plug	Polyamide 6-6
903.3	Bored plug	-----
932.1	Spring retaining ring	Steel
970.1	Identity plate	Adhesive polyester
970.2	Instruction notice	Untearable paper
970.3	"No Air" sticker	Adhesive polyester

■ Parts included in the spare parts kit

Technical data

Environment

Housing material: molded light alloy AS9U3
 Coating: black cataphoresis
 Protection level: IP 67 with output via packing-gland, IP 65 with output via 12-pin connector
 Resistance to impacts: 5g
 Resistance to vibrations: According to standard IEC 60068-2-6 Fc test. Frequency: 5 to 100 Hz. Move ± 1 mm. Acceleration $\pm 0,7$ g.
 Electromagnetic compatibility: EN 61000-6-2; EN 61000-6-4
 Test standards (EMC): EN 55011; EN 61000-4-2; EN 61000-4-3; EN 61000-4-4; EN 61000-4-5; EN 61000-4-6
 Working temperature from $- 20^{\circ}\text{C}$ up to $+ 80^{\circ}\text{C}$

Electric connections

Two packing-gland M 20 plastic (for wire dia. 6 to 12) or metallic (for wire dia. 7 to 12) or one 12-pin cranked plastic connector (R 1149 and RA 1149).

Two packing-gland M 20 plastic or metallic or two 12-pin cranked plastic connectors (R 1140, RA 1140, R 1141 and RA 1141).

Overall dimensions (mm) and weight (kg)

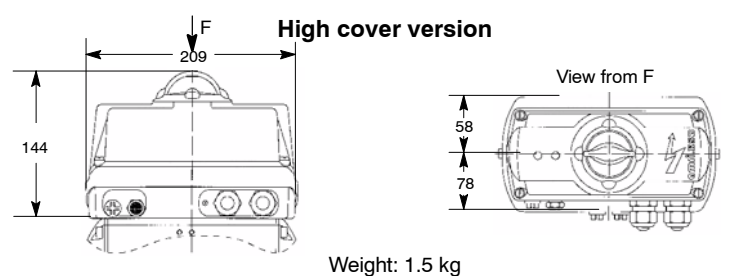
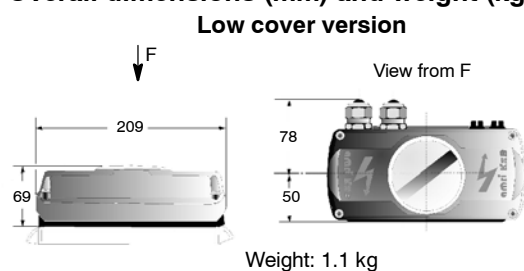

Position detection by microswitches on printed circuit board AMTROBOX R 1140 and R1149

- Detection by 2 microswitches: 1 sur opening and 1 on closing, changeover function, trigger action adjustable by cam on each microswitch.
- Connection by 2 packing-gland (plastic or metallic) or connector 12-pin (refer page 12).

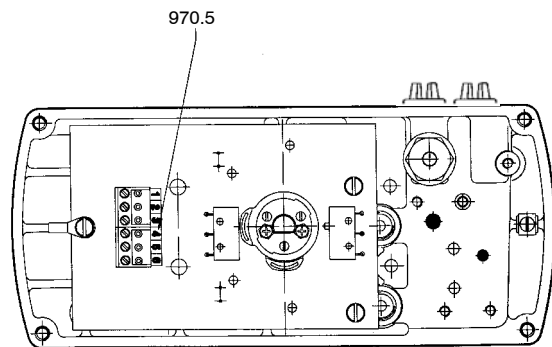
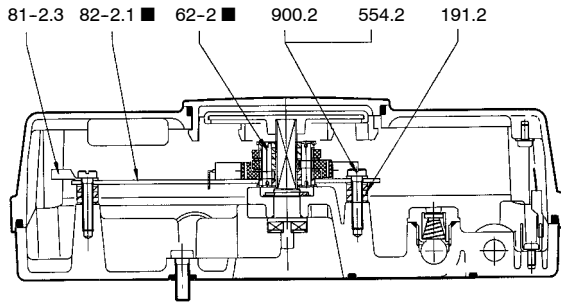
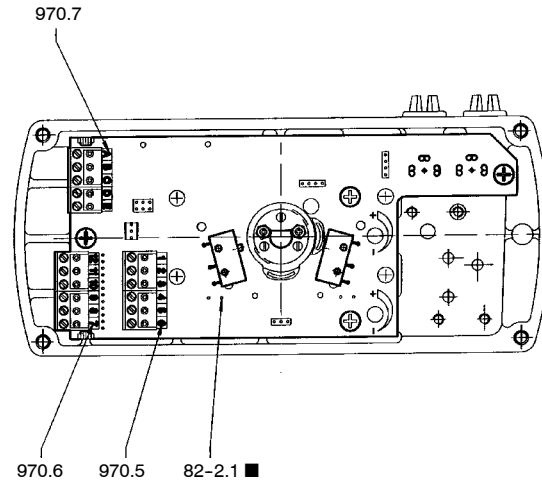
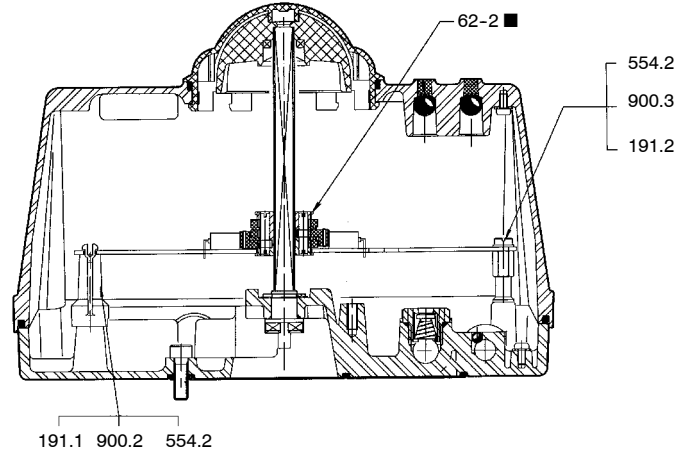
AMTROBOX R 1149

AMTROBOX R 1140

Item	Designation	Materials
191.1	Support of printed circuit board (AMTROBOX R 1140)	Acetal
191.2	Support of printed circuit board	Polyamide 6-6
554.2	Plain washer	Stainless steel
62-2 ■	3 cams sub-assembly	Acetal + 30% fibreglass
81-2.3	Round cable terminal (AMTROBOX R 1149)	-----
82-2.1 ■	Printed circuit board with 2 microswitches	-----
900.2	Cheese-head screw	A2-70 stainless steel
900.3	Cheese-head screw	A2-70 stainless steel
970.5	Item sticker	Adhesive aluminium
970.6	Item sticker	Adhesive aluminium
970.7	Item sticker	Adhesive aluminium

■ Parts included in the spare parts kit

Microswitches characteristics

• Manufacturer:	CROUZET	
• Material:	Housing Button Contact Membrane	Polyester UL94V0 Polyester Ag/Ni gold plated Silicone
• Rating:	Cut-off capacity 6 A under 24 VDC and 250 VAC	
• Life:	Electrical	under I = 5 A 7 x 10 ⁴ operating cycles under I = 1 A 3 x 10 ⁵ operating cycles under I = 0.2 A 10 ⁶ operating cycles
	Mechanical	2 x 10 ⁶ operating cycles
• Resistance to vibrations:	Standard: CEI 60068-2-6 / 3 axis / 50 g from 10 to 500 Hz	
• Electromagnetic compatibility:	EN 50081-2; EN 50082-2	
• Electric connection:	Welded on circuit	
• Protection level	IP 67	

Breaking capacity according to the standard CEI 60947-5-1: 6000 cycles

I (A)	Alternating current (AC)				
	24 V	48 V	110 to 127 V	220 to 240 V	380 to 440 V
AC-12	6	6	6	6	5
AC-13	2	1,5	1	1	0,5
AC-14	≤ 72 VA				
AC-15	2	1,5	1	1	0,5

I (A)	Direct current (DC)			
	24 V	48 V	110 to 127 V	220 to 240 V
DC-12	6	2	0,4	0,2
DC-13	3	1	0,2	0,1
DC-14	0,6	0,15	0,02	0,01

I (A) : Allowable maximum intensity (A)

AC-12: Control of resistive loads and solid state loads with isolation by optocouplers

AC-13: Control of solid state loads with transformer isolation

AC-14: Control of small electromagnetic loads (≤ 72 VA)

AC-15: Control of electromagnetic loads (≥ 72 VA)

DC-12: Control of resistive loads and solid state loads with isolation by optocouplers

DC-13: Control of electromagnets

DC-14: Control of electromagnetic loads having economy resistors in circuit

This microswitch is designed to operate indifferently on circuits of bi-level type: low intensity (1 mA, 4 V minimum) or medium intensity (6 A maximum). However, a microswitch must change over only one and same type of PCB during its all use.

- Internal wiring diagram

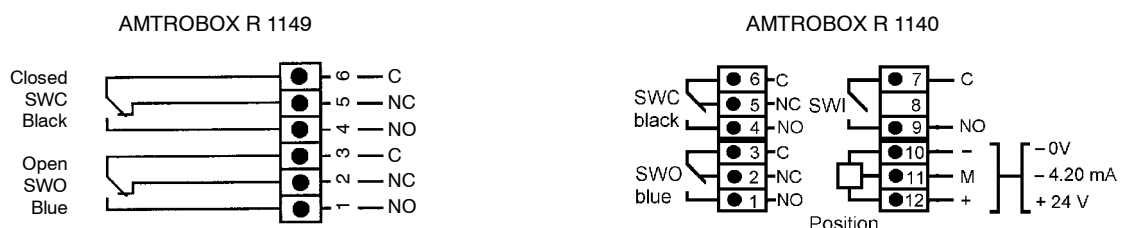
Option : Intermediate detection position by third microswitch on printed circuit board - AMTROBOX R 1140

One third switch, identical to the two previous ones, can be fitted and allows either to couple one of open or closed microswitch or to be adjusted on any point of the travel (ajustable on 90°).

Adjustment of cams for position detection: See page 9

Position detection by inductive proximity detectors on printed circuit board AMTROBOX R 1141 and AMTROBOX R 1149

- Detection by 2 inductive proximity detectors: 1 on opening and 1 on closing, changeover function, trigger action by cam on each detector.
- Connection by 2 packing-gland (plastic or metallic) or connector 12-pin (refer page 12)

AMTROBOX R 1149

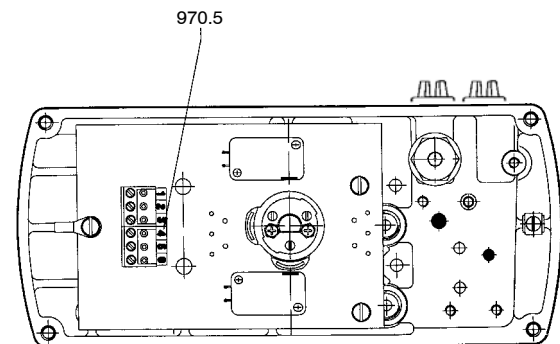
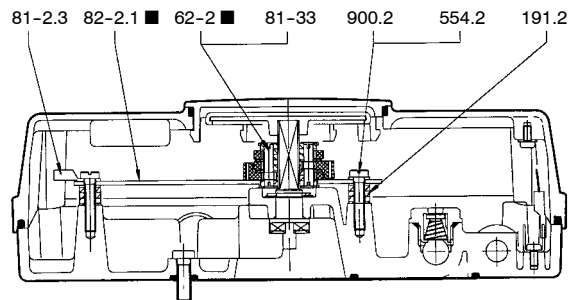

AMTROBOX R 1141

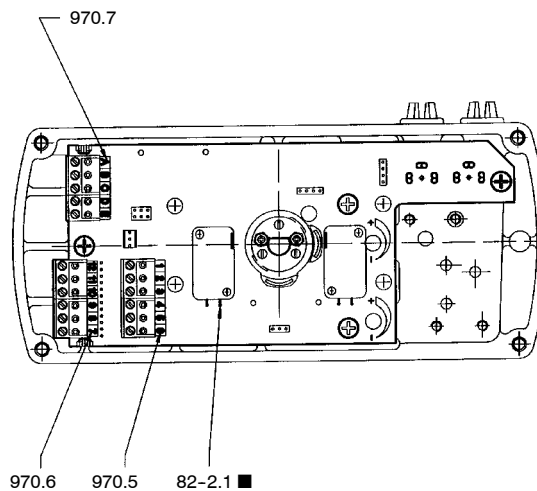
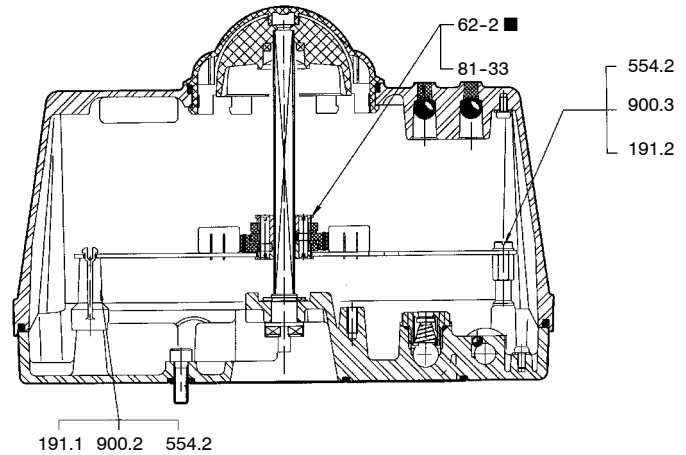

Item	Designation	Materials
191.1	Support of printed circuit board (AMTROBOX R 1140)	Acetal
191.2	Support of printed circuit board	Polyamide 6-6
554.2	Plain washer	Stainless steel
62-2 ■	3 cams sub-assembly	Acetal + 30% fibreglass
81-2.3	Round cable terminal (AMTROBOX R 1149)	-----
81-33	Detection sheet	Steel
82-2.1 ■	Printed circuit board with 2 detectors	-----
900.2	Cheese-head screw	A2-70 stainless steel
900.3	Cheese-head screw	A2-70 stainless steel
970.5	Item sticker	Adhesive aluminium
970.6	Item sticker	Adhesive aluminium
970.7	Item sticker	Adhesive aluminium

■ Parts included in the spare parts kit

Detectors characteristics

• Manufacturer:	IFM
• Material:	Housing in polybutylenetherephthalate
• Operating voltage:	5 to 36 V DC
• Current rating/continuous and peak:	200 mA
• Minimum load current:	4 mA
• Maximum voltage drop:	< 4.6V
• Residual current:	< 0.8 mA
• Maximum switching frequency:	2 kHz
• Output status indication:	by yellow LED
• Resistance to impacts:	5 g in accordance with CEI 68-2-27
• Resistance to vibrations:	Standard: CEI 60068-2-6 / 3 axis / 50 g from 10 to 500 Hz
• Electromagnetic compatibility:	EN 50081-2; EN 50082-2
• Electric connection:	Welded on circuit

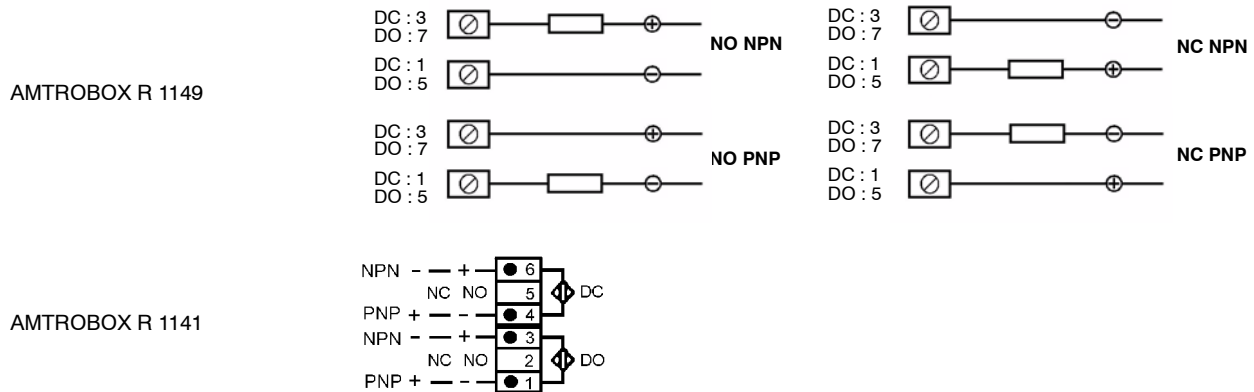
Internal wiring diagram
Customer connection for the detectors

Adjustment of cams for position detection

The limit switches or detectors are factory adjusted. It is not necessary to re-adjust before valve mounting on site. Nevertheless, if you wish to re-adjust after a maintenance operation, proceed as follows:

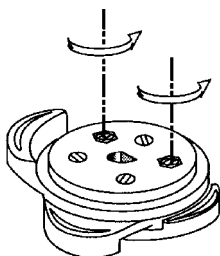
- Remove the cover of the AMTROBOX.
- Put the disc in extreme position (opening or closing).
- Unscrew the two metal screws one turn.
- Adjust triggering of the required detector by turning the coloured screw corresponding to the colour of the cam to adjust.
- Proceed in the same manner with the opposite switch.
- Each cam is adjusted independently and the adjustment does not affect in any way the adjustment of the other cam.
- When adjustments are completed, slightly tighten the two metal screws to prevent adjustments being changed.
- Replace the cover of the box.

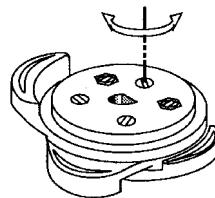

1 - Loosen the metal screws



2 - Adjust the cams

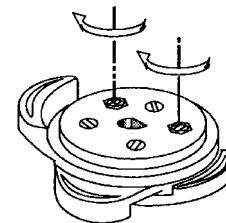

3 - Tighten the metallic screws

Position detection by microswitches or inductive proximity detectors fitted on metallic sheet - AMTROBOX RA 1140, RA 1141 et RA 1149

Various types of microswitches or inductive proximity detectors can be fitted on a metallic sheet in the AMTROBOX for extreme positions indication (opening and closing).

Connection is done via:

- one 12-pin connector (RA 1149),
- two 12-pin connectors (RA 1140 and RA 1149).

In this version, the box can be equipped:

- either with one position detector on closing,
- or with one position detector on opening,
- or with one detector on closing and one detector on opening.

AMTROBOX RA 1140 and RA 1141

Microswitches

Manufacturer	Type	Reference	Size	Codification
CROUZET	electric	83-186-069-FD0 + lever 170A R24	V4	RA 114.-A111....

Inductive proximity detectors

Manufacturer	Type	Reference	Size	Codification
BAUMER	PNP-NO	IFFK 10.24.31 - 3 lugs 4.8	V3	RA 114.-H311....
IFM EFFECTOR	PNP-NO	IS-3003-BPOG/IS 5031 - cable 3 wires	V3	RA 114.-H211....
	PNP-NC	IS-3003-APOG/IS 5032 - cable 3 wires	V3	RA 114.-H212....
	CC Quadronorm	IS-2002-FROG/IS 5026 - cable 2 wires	V3	RA 114.-HA31....
	CC/CA	IN-2004-ABOA/IN0081 - cable 2 wires	40 x 26 x 12	RA 114.-JA31....
PEPPERL & FUCHS	CC-NO	NBN4-12GM40-Z0 - cable 2 wires	M12	RA 114.-MA32....
	PNP-NC	NBB2-V3-E2-V5	V3	RA 114.-H312....
TELEMECANIQUE	CC-NO	XS512B1DAL2 - cable 2 wires	M12	RA 114.-MA31....
	CC-NO	XS518B1DAM12 - cable 2 wires	M18	RA 114.-PA31....

AMTROBOX RA 1149

Microswitches

Manufacturer	Type	Reference	Size	Codification
CROUZET	electric	83-186-069-FD0 + lever 170A R24	V4	RA 1149-A111....

Inductive proximity detectors

Manufacturer	Type	Reference	Size	Codification
BAUMER	PNP-NO	IFFK 10.24.31 - 3 lugs 4.8	V3	RA 1149-H311....
IFM EFFECTOR	PNP-NO	IS-3003-BPOG/IS 5031 - cable 3 wires	V3	RA 1149-H211....
	PNP-NC	IS-3003-APOG/IS 5032 - cable 3 wires	V3	RA 1149-H212....
	CC Quadronorm	IS-2002-FROG/IS 5026 - cable 2 wires	V3	RA 1149-HA31....
	CC/CA	IN-2004-ABOA/IN0081 - cable 2 wires	40 x 26 x 12	RA 1149-JA31....
PEPPERL & FUCHS	PNP-NC	NBB2-V3-E2-V5	V3	RA 1149-H312....

Please consult us for the technical characteristics of these components.

Options

Angle sensor - AMTROBOX R 1140, RA 1140, R 1141 and RA 1141

A potentiometric angle sensor (4,7 kΩ on 100°) gives a measure of the valve position.

Feed-back position - AMTROBOX R 1142 and R 1143

A transmitter can be associated with the angle sensor in order to transform the measure given by the angle sensor in a 4–20 mA signal.

This transmitter can be:

- active: it generates the 4–20 mA signal and may be supplied in 24 VDC (3-wire wiring),
- passive: it has the intensity changed in the current loop relating to the position measured by the angle sensor (2-wire wiring).

4–20 mA active feed-back position module (3 wires)

Parameter	Minimal	Nominal	Maximal	Unit
Supply voltage	18	24	30	V
Output signal	0.6	/	21	mA
Loop resistance	0	/	550	Ω
Zero adjustment (4 mA)	0.6	4	5	mA
Span adjustment (20 mA)	12	20	21	mA
Temperature range	-20	/	+70	°C
Temperature influence (from -20 to +70 °C)		± 0.12	± 0.28	% FS
Hysteresis and dead band		± 0.05	± 0.2	% FS
Non linearity		± 0.05	± 0.2	% FS

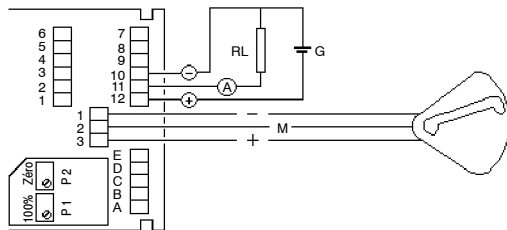

RL = 0 Ω max. for U = 18 VCC
 RL = 550 Ω max. for U = 30 VCC

Connection defect

Wire + of sensor open	2.8 mA
Wire - of sensor open	23 mA
Wire M of sensor open	3.15 mA
No sensor	2.8 mA

4–20 mA passive feed-back position (2 wires)

Parameter	Minimal	Nominal	Maximal	Unit
Supply voltage	7.5	21.5	36	V
Output signal	3.6	/	28	mA
Loop resistance $[(U_{\text{supply}} - 7.5V)/0.02A]$	0	700	1425	Ω
Zero adjustment (4 mA)	2	4	11	mA
Span adjustment (20 mA)	16	20	26	mA
Temperature range	-20	/	+70	°C
Temperature influence (from -20 to +70 °C)		± 0.12	± 0.28	% FS
Hysteresis and dead band		± 0.05	± 0.2	% FS
Non linearity		± 0.05	± 0.2	% FS

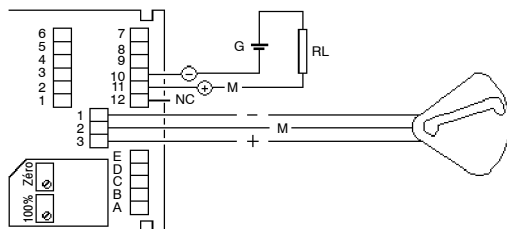

RL = 1425 Ω max. for U = 36 VCC
 RL = 700 Ω max. for U = 21.5 VCC
 RL = 0 Ω for U = 7.5 VCC

Angle sensor defect

Wire 1 open (-)	I output = 26 mA
Wire 2 open (M)	I output = 1.7 mA
Wire 3 open (+)	I output = 1.2 mA

Heating resistance - AMTROBOX R 1140,RA 1140, R 1141, RA 1141, R 1179 and RA 1149

This option allows to warm continuously the inside of the box in order to avoid the condensation phenomenons encountered in the hazardous areas (tropical environment, humidity, ...).

This option is available in two kits:

Voltage	Regulated temperature	Consumption	Kit reference
12 VDC -24 VDC	40° C	10 W	42095198
110 VAC - 230 VAC	50° C	10 W	42095199

The wiring is achieved by connecting the two supply wires to the no-polarized resistance through the packing-gland.

12-pin connector - AMTROBOX R 1140,RA 1140, R 1141, RA 1141, R 1179 and RA 1149

As an option, AMTROBOX can be equipped with two cranked 12-pin connectors, max. connection capacity of wiring terminal 1.5 mm²:

- AMTROBOX R 1140, RA 1140, R 1141 and RA 1141 : 2 connectors,
- AMTROBOX R 1140, RA 1140, R 1141, RA 1141, R 1149 and RA 1149 : 1 connector.

AMTROBOX R 1140, RA 1140, R 1141
RA 1141, R 1149 and RA 1149
1 12-pin connector

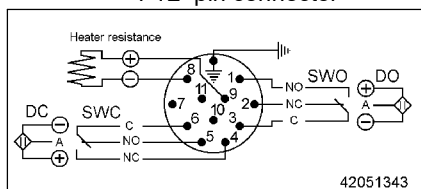

AMTROBOX R 1140, RA 1140, R 1141and RA 1141
2 12-pin connectors

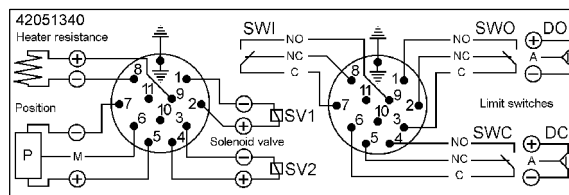

Fieldbus - AMTROBOX

Ensuring the communication function by fieldbus is simply realizable by integrating an electronic card in the box.

The fieldbus technology mainly allows to simplify the wiring of control/monitoring on on/off applications and to reduce the installation costs.

AMTROBOX are compatible with the bus communication protocols Profibus DP (R1140 and R1141) and AS-i (R1149).

For more information, please consult the type series booklet ref. 8514.11.

This leaflet is not contractual and may be amended without notice.

06.05.08

85251/7-10