

Applications

- All sectors of Navy construction, Water and Industry markets.
- AMTROBOX R is designed for harsh applications.

General information

- AMTROBOX R can be mounted directly on actuators compatible with VDI/VDE 3845 interface:
 - ACTO / DYNACTO hydraulic actuators,
 - ACTAIR / DYNACTAIR pneumatic actuators,
 - MR manual actuators.
- No bracket is necessary, overall dimensions are reduced.
- This robust box integrates the open/close detection box:
 - by switches
 - by proximity sensors.
- Its adjustable cams device for position detection makes it very reliable and easy to adjust.
- The electrical connections are made by packing-gland.

Protection

- IP 68

Temperature range

- From -20°C up to $+70^{\circ}\text{C}$

Materials

- Its cataphoresis coating and the paint ensure a good resistance in corrosive environments.
- Housing: cast iron

Standard variants

- Position detection by standard microswitches or inductive proximity detectors on printed circuit: R 1187
- Position detection by special microswitches or inductive proximity detectors on metallic plate: RA 1187

Options

- Valve position feed-back by potentiometer or 4-20 mA transmitter.
- Visual indication of valve position by flag.
- Submersible version
- Fieldbus
- Heating resistance
- For applications in explosive areas, KSB has developed an intrinsically safe version: AMTROBOX R EEx-ia (R 1188). Refer to Type series booklet no. 8524.11/-10.

This leaflet is also to be used as a start-up guide
ref. 42 057 233.

Contents

| | Page |
|--|------|
| General technical data | 2 |
| Overall dimensions and weight | 2 |
| Construction | 3 |
| Position detection by standard microswitches or proximity detectors on printed circuit - Box R 1187 | 5 |
| Position detection by special microswitches or proximity detectors on metallic plate - Box RA 1187 | 6 |
| Options | |
| - Microswitch on intermediate position - Box R 1187-1 | 7 |
| - Heating resistance - Box RA 1187 | 7 |
| - Feed-back position 0° to 90° by resistive angle - Any box | 7 |
| - Feed-back position 0° to 90° by 4-20 mA transmitter - Any box | 8 |
| - Fieldbus - Box R 1187 | 9 |
| - Visual indication position by flag - Any box | 9 |
| - Submersible version - Any box | 9 |
| Commissioning | |
| - Warning | 10 |
| - Mounting on actuator | 11 |
| - Open/close position adjustment | 11 |
| - Angle sensor adjustment | 11 |
| - 4-20 mA transmitter adjustment | 12 |
| - Electric connection | 12 |
| - Wiring diagrams | 12 |
| - Assembly fitting instructions for installation of cable gland type T3CDS | 13 |
| Product features - to our Customers' Benefit | 16 |

General technical data

| Environment | |
|-----------------------------------|--|
| - Protection level: | Standard: IP 68 (30 m, 72 hours); Option: IP 68, 30 m permanent according to ABS SC180 |
| - Resistance to vibrations: | According to "Test programm Lloyd's Register - vibration test 1" and IEC 60068-2-6 Test Fc standard. Fréquency: 5 to 100 Hz. Displacement ± 1 mm. Acceleration: ± 0.7 g. |
| - Température de fonctionnement : | From - 20° C up to + 65° C or + 70° C (from - 4° F up to + 149° F or + 158° F) |
| - Electromagnetic compatibility: | |
| - generic standards | EN 61000-6-2; EN 61000-6-4 |
| - fundamental standards | EN 55011; EN 61000-4-2; EN 61000-4-3; EN 61000-4-4; EN 61000-4-5 EN 61000-4-6 |
| Housing | |
| - Material: | JL 1040 cast iron |
| - Coating: | Cataphoresis (25 µm)+ black paint (125 µm) |
| - Position signalisation: | by pointer under sight glass or by flag |
| - Electrical connection : | By packing-gland (metallic or plastic) M20x1.5 or M25x1.5 for cable dia. 6 to 18 mm |

Overall dimensions (mm) and weight (kg)

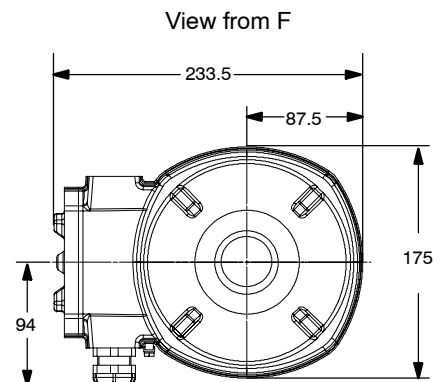
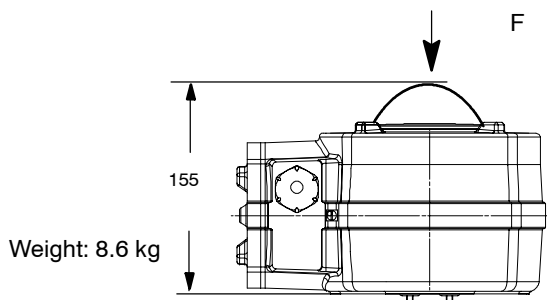

Construction

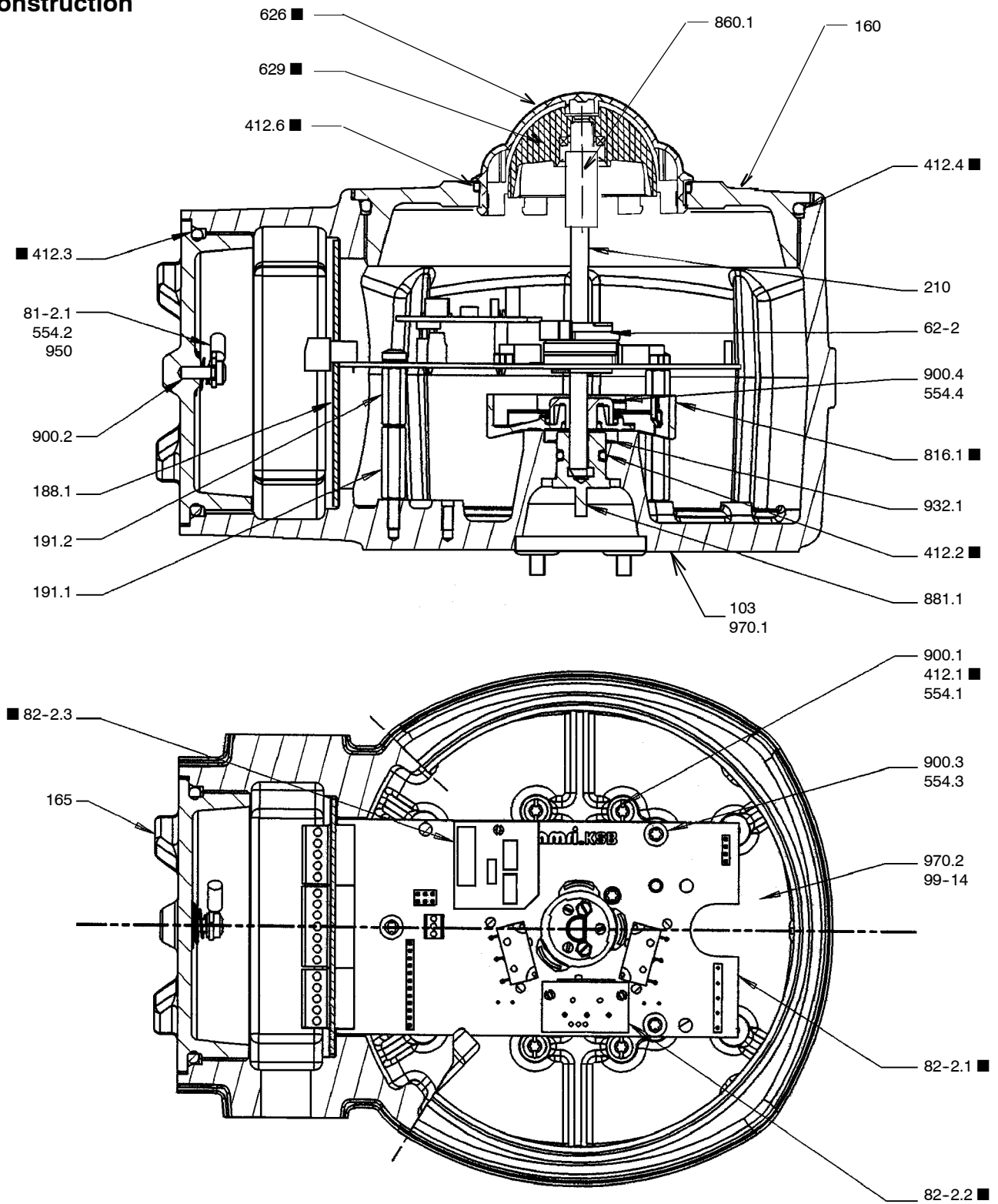

■ Parts included in the spare parts kit

| Item | Designation | Materials |
|----------|--|---------------------------|
| 103 | Housing | JL 1040 cast iron |
| 160 | Cover | JL 1040 cast iron |
| 165 | Electric compartment cover | JL 1040 cast iron |
| 188.1 | Fixing plate | Steel |
| 191.1 | Support of printed circuit board | Nickeled brass |
| 191.2 | Support of printed circuit board | Nickeled brass |
| 210 | Operating shaft | 316 L stainless steel |
| 412.1 ■ | O-Ring | Nitrile |
| 412.2 ■ | O-Ring | Nitrile |
| 412.3 ■ | O-Ring | Nitrile |
| 412.4 ■ | O-Ring | Nitrile |
| 412.7 ■ | O-Ring | Nitrile |
| 554.1 | Plain washer | Stainless steel |
| 554.2 | Plain washer | Stainless steel |
| 554.3 | Plain washer | Stainless steel |
| 554.4 | Tooth lock washer | Steel |
| 62-2 | Cam sub-assembly | Acetal |
| 626 ■ | Sight glass | Transparent polycarbonate |
| 629 ■ | Pointer | Polyamide 6.6 |
| 81-2.1 | Ground wire sub-assembly | Copper + PVC |
| 816.1 ■ | Angle sensor | Acetal |
| 82-2.1 ■ | Printed circuit board with 2 microswitches or 2 detectors | ----- |
| 82-2.2 ■ | Printed circuit board with intermediate microswitch (option) | ----- |
| 82-2.3 ■ | Printed circuit board for position feed-back (option) | ----- |
| 860.1 | Adjustment adaptation sleeve | Stainless steel |
| 881.1 | Hub | Brass |
| 900.1 | Cheese-head screw | Stainless steel |
| 900.2 | Self-tapping screw | Stainless steel |
| 900.3 | Cheese-head screw | Stainless steel |
| 900.4 | Cheese-head screw | Steel |
| 932.1 | Self locking | Steel |
| 950 | Conic spring | Stainless steel |
| 970.1 | Identity plate | Polyester |
| 970.2 | Instruction guide | Paper |
| 99-14 | Dessicant bag | ----- |

■ Spare parts available in kit

Position detection by standard microswitches on printed circuit board - Box R 1187-1.....

- Detection by 2 microswitches: 1 on opening and 1 on closing, changeover function, trigger action adjustable by cam on each microswitch.
- Connection: refer page12.

Microswitches characteristics

| | | |
|--------------------------------|--|--|
| Manufacturer | CROUZET | |
| Material: | Housing | Polyester UL94V0 |
| | Button | Polyester |
| | Contact | Ag/Ni gold plated |
| | Membrane | Silicone |
| Rating: | Cut-off capacity 6 A under 24 VDC and 250 VAC | |
| Life: | Electrical | under I = 5 A 7 x 10 ⁴ operating cycles under I = 1 A 3 x 10 ⁵ operating cycles under I = 0.2 A 10 ⁶ operating cycles |
| | Mechanical | 2 x 10 ⁶ operating cycles |
| Resistance to vibrations: | Standard: CEI 60068-2-6 / 3 axis / 50g from 10 to 500 Hz | |
| Electromagnetic compatibility: | EN 50081-2; EN 50082-2 | |
| Electric connection: | Welded on circuit | |
| Protection level | IP 67 | |

Breaking capacity according to the standard CEI 60947-5-1: 6000 cycles

| I (A) ↘ | Alternating current (AC) | | | | |
|---------|--------------------------|------|--------------|--------------|--------------|
| | 24 V | 48 V | 110 to 127 V | 220 to 240 V | 380 to 440 V |
| AC-12 | 6 | 6 | 6 | 6 | 5 |
| AC-13 | 2 | 1,5 | 1 | 1 | 0,5 |
| AC-14 | ≤ 72 VA | | | | |
| AC-15 | 2 | 1,5 | 1 | 1 | 0,5 |

| I (A) ↘ | Direct current (DC) | | | |
|---------|---------------------|------|--------------|--------------|
| | 24 V | 48 V | 110 to 127 V | 220 to 240 V |
| DC-12 | 6 | 2 | 0,4 | 0,2 |
| DC-13 | 3 | 1 | 0,2 | 0,1 |
| DC-14 | 0,6 | 0,15 | 0,02 | 0,01 |

I (A) : Allowable maximum intensity (A)

AC-12: Control of resistive loads and solid state loads with isolation by optocouplers

AC-13: Control of solid state loads with transformer isolation

AC-14: Control of small electromagnetic loads (≤ 72 VA)

AC-15: Control of electromagnetic loads (≥ 72 VA)

DC-12: Control of resistive loads and solid state loads with isolation by optocouplers

DC-13: Control of electromagnets

DC-14: Control of electromagnetic loads having economy resistors in circuit

This microswitch is designed to operate indifferently on circuits of bi-level type: low intensity (1 mA, 4 V minimum) or medium intensity (6 A maximum). However, a microswitch must change over only one and same type of PCB during its all use.

Position detection by standard inductive proximity detectors on printed circuit board Box R 1187-2.....

- Detection by 2 inductive proximity detectors: 1 on opening and 1 on closing, changeover function, trigger action by cam on each detector.
- Connection: refer page 11.

Detectors characteristics

| | |
|-------------------------------------|---|
| Manufacturer | IFM |
| Material: | Housing in polybutylenetherephthalate |
| Operating voltage: | 5 to 36 V DC |
| Current rating/continuous and peak: | 200 mA |
| Minimum load current: | 4 mA |
| Maximum voltage drop: | < 4.6V |
| Residual current: | < 0.8 mA |
| Maximum switching frequency: | 2 kHz |
| Output status indication: | by yellow LED |
| Resistance to impacts: | 5 g in accordance with CEI 68-2-27 |
| Resistance to vibrations: | According to "Test programm Lloyd's Register - vibration test 1" and IEC 60068-2-6 Test Fc standard. Fréquency: 5 to 100 Hz. Displacement ± 1 mm. Acceleration: ± 0.7 g |
| Electromagnetic compatibility: | EN 50081-2; EN 50082-2 |
| Electric connection: | Welded on circuit |

Position detection by special microswitches or inductive proximity detectors fitted on metallic plate - Box RA 1187

Various types of microswitches or inductive proximity detectors can be fitted on a metallic plate in the AMTROBOX R for extreme positions indication (opening and closing).

In these versions, the box can be equipped:

- either with one microswitch or proximity detector on closing,
- or with one microswitch or proximity detector on opening,
- or with one microswitch or proximity detector on closing and one microswitch or proximity detector on opening.

Microswitches

| Manufacturer | Type | Reference | Size | Codification |
|--------------|----------|---------------------------------|------|------------------|
| CROUZET | electric | 83-186-069-FD0 + lever 170A R24 | V4 | RA 1187-A111.... |

Inductive proximity detectors

| Manufacturer | Type | Reference | Size | Codification |
|-----------------|---------------|--------------------------------------|--------------|------------------|
| BAUMER | PNP-NO | IFFK 10P11A11 - 3 lugs 4.8 | V3 | RA 1187-H311.... |
| IFM EFFECTOR | PNP-NO | IS-3003-BPOG/IS 5031 - cable 3 wires | V3 | RA 1187-H211.... |
| | PNP-NC | IS-3003-APOG/IS 5032 - cable 3 wires | V3 | RA 1187-H212.... |
| | CC Quadronorm | IS-2002-FROG/IS 5026 - cable 2 wires | V3 | RA 1187-HA31.... |
| | CC/CA | IN-2004-ABOA/IN0081 - cable 2 wires | 40 x 26 x 12 | RA 1187-JA31.... |
| PEPPERL & FUCHS | CC-NO | NBN4-12GM40-Z0 - cable 2 wires | M12 | RA 1187-MA32.... |
| | PNP-NC | NBB2-V3-E2-V5 | V3 | RA 1187-H312.... |
| TELEMECANIQUE | CC-NO | XS512B1DAL2 - cable 2 wires | M12 | RA 1187-MA31.... |
| | CC-NO | XS518B1DAL12 - cable 2 wires | M18 | RA 1187-PA31.... |

For technical characteristics of these components, please consult us.

Options

Microswitch on intermediate position - Box R 1187-1.....

A third microswitch identical to the two previous ones can be fitted on the printed circuit board and allows either to couple one of open or closed microswitch or to be adjusted on any point of the travel (adjustable on 90°).

Heating resistance

This option allows to warm continuously the inside of the box in order to avoid the condensation phenomenons encountered in the hazardous areas (tropical environment, humidity, ...).

This option is available in two kits:

| Voltage | Regulated temperature | Consumption | Kit reference |
|-------------------|-----------------------|-------------|---------------|
| 12 VDC - 24 VDC | 40° C | 10 W | 42095198 |
| 110 VAC - 230 VAC | 50° C | 10 W | 42095199 |

The wiring is achieved by connecting the two supply wires to the no-polarized resistance through the packing-gland.

Feed-back position 0° to 90° by resistive angle sensor - Any box

AMTROBOX R can be equipped with feed-back position sensor.

So, the valve position is transmitted during its whole travelling angle by means of a variable resistance between 0 Ω and 4.7kΩ.

In instrumentation technology, the use of a potentiometer to transmit a signal under voltage exposes the user to electromagnetic pollution, mainly for high distance transmissions or in very polluted environment.

The use of a 4-20 mA current loop is always preferable due to its better electromagnetic strength (see page 8).

Technical characteristics of angle sensor

| | Min. | Nominal | Max. | Units |
|-------------------------------|------|---------|---------------------|------------|
| Mechanical travel | 80 | 90 | 105 | Degrees |
| Electrical span | 3.58 | 4.03 | 4.7 | kΩ |
| Maximal current | | | 1 | mA |
| Mechanical and lectrical life | | | > 5.10 ⁶ | Travel O/C |

Other values are available: 1 kΩ, 2.2 kΩ and 4.7 kΩ. Please consult us for the characteristics.

Feed-back position 0° to 90° by 4-20 mA transmitter

A transmitter can be associated to the the angle sensor in order to convert the measure in a 4-20 mA signal insuring a good immunity to the electrical disturbances. This transmitter can be:

- active : it generates the 4-20 mA signal and must be supplied in 24 VDC (3 wires) - Box R 1187,
- passive:it changes the intensity in the current loop in accordance with the position measured by the angle sensor (2 wires) - Boxes R 1187 and RA 1187..

4-20 mA active feed-back position module (3 wires) - Boxes R 1187 and RA 1187

| Parameter | Minimal | Nominal | Maximal | Unit |
|--|---------|---------|---------|------|
| Supply voltage | 18 | 24 | 30 | V |
| Output signal | 0.6 | / | 21 | mA |
| Loop resistance | 0 | / | 550 | Ω |
| Zero adjustment (4 mA) | 0.6 | 4 | 5 | mA |
| Span adjustment (20 mA) | 12 | 20 | 21 | mA |
| Temperature range | -20 | / | +70 | °C |
| Temperature influence (from -20 to +70 °C) | | ± 0.12 | ± 0.28 | % FS |
| Hysteresis and dead band | | ± 0.05 | ± 0.2 | % FS |
| Non linearity | | ± 0.05 | ± 0.2 | % FS |

4-20 mA passive feed-back position (2 wires) - Box R 1187

| Parameter | Minimal | Nominal | Maximal | Unit |
|--|---------|---------|---------|------|
| Supply voltage | 7.5 | 21.5 | 36 | V |
| Output signal | 3.6 | / | 28 | mA |
| Loop resistance [(U _{supply} - 7.5V)/0.02A] | 0 | 700 | 1425 | Ω |
| Zero adjustment (4 mA) | 2 | 4 | 11 | mA |
| Span adjustment (20 mA) | 16 | 20 | 26 | mA |
| Temperature range | -20 | / | +70 | °C |
| Temperature influence (from -20 to +70 °C) | | ± 0.12 | ± 0.28 | % FS |
| Hysteresis and dead band | | ± 0.05 | ± 0.2 | % FS |
| Non linearity | | ± 0.05 | ± 0.2 | % FS |

4-20 mA passive feed-back position (2 wires) - Box RA 1187

| Parameter | Minimal | Nominal | Maximal | Unit |
|--|---------|---------|---------|------|
| Supply voltage | 10 | 24 | 30 | V |
| Output signal | 3.8 | / | 22 | mA |
| Loop resistance [(U _{supply} - 7.5V)/0.02A] | 0 | 700 | 1050 | Ω |
| Zero adjustment (4 mA) | 3.8 | 4 | 4.2 | mA |
| Span adjustment (20 mA) | 18 | 20 | 22 | mA |
| Temperature range | -20 | / | +65 | °C |
| Temperature influence (from -20 to +70 °C) | | ± 0.15 | | % FS |
| Hysteresis and dead band | | ± 0.15 | | % FS |
| Non linearity | | ± 1 | | % FS |

Detection of faulty box or angle sensor connection

| Active feed-back position (3 wires) | | Passive feed-back position (3 wires) | | | |
|-------------------------------------|---------|--------------------------------------|-------------------|-----------------------------|------------------|
| Box R 1187 | | Box R 1187 | | Box RA 1187 | |
| Connection defect | | Angle sensor defect | | Transmitter response | |
| Wire + of sensor open | 2.8 mA | Wire 1 open (-) | I output = 26 mA | Wire 1 open | I output ≈ 20 mA |
| Wire - of sensor open | 23 mA | Wire 2 open (M) | I output = 1.7 mA | Wire 2 open | I output ≈ 25 mA |
| Wire M of sensor open | 3.15 mA | Wire 3 open (+) | I output = 1.2 mA | Wire 3 open | I output ≤ 4 mA |
| No sensor | 2.8 mA | | | No sensor | I output ≈ 25 mA |

On/off fieldbus - Box R 1187

AMTROBOX R can be connected to fieldbus.

The reduction of cable lengths, cable ways quantity and connecting points constitute more significant savings in the case of harsh environments.

Various communication protocols are available (AS-i, Profibus DP) and allow to digitalize the information of travel limit switches.

Bus characteristics

| Protocol | AS-i v3.0 | Profibus DP | | |
|-----------------------------|--|--|--------------------------------------|----------------------------------|
| Topology | Bus, tree and ring | Bus, tree with repeaters | | |
| Cable type | 2-wire cable AS-i power | 4-wire shielded cable: twisted pair and 24 VDC power supply | | |
| Speed and length of network | Cycle time 10 msec. | Speed (kbit/s) | length (without repeater) | Length (with repeater) |
| | Length from 100 metres to 300 metres with repeaters | 9,6 19,2 45,45 93,75 187,5 | 1200 m 1200 m 1200 m 1200 m | 10 km 10 km 10 km 10 km |
| Profil / version | S-BAE / version 3.0 S-30F / version 3.0 | 500 1500 | 1000 m 400 m 200 m | 6 km 1 km 600 m |
| Max. quantity stations | 62 profile S-BAE 31 profile S-30F | 32 per segments - 126 max. | | |
| Bus access | Polling | Polling master/slave Token rings between masters | | |
| Adressing | E ² PROM | by encoders | | |
| Electric consumption | 3 w (max.) | 3 w (max.) | | |
| Supply | 26,5 to 31,5 VCC | 24 VCC ± 15% | | |

Visual indication by flag - Any box

As an option, AMTROBOX R EEx-ia can be equipped with a flag allowing to visualize the valve position at great distance, thanks to a melaminated sheet.

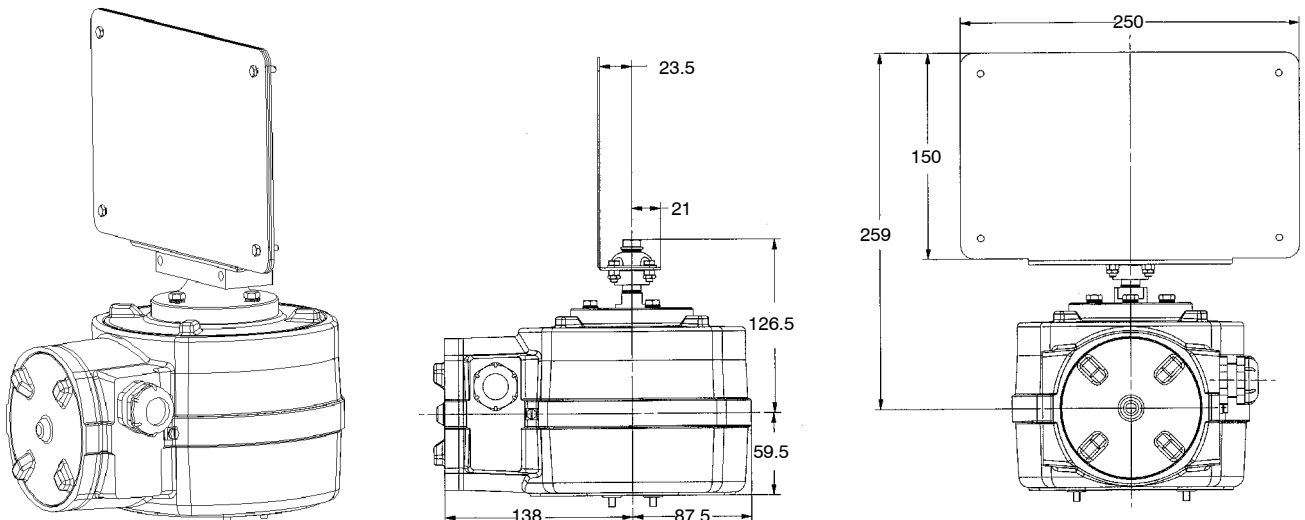

In this version, the top cover is without position visual indication.

Submersible version (IP 68 (30m, 72 permanent hours in accordance with ABS SC180) - All boxes

This version is equipped with a top cover without position visual indication and a specific packing gland.

Cable diameter (outer sheath): 6 to 13.4 mm,

Cable diameter (inner sheath): 3.1 to 8.6 mm,

Armour wires crawling for electrical continuity and mechanical crawling.

Commissioning

WARNING



CAUTION !

Electric wiring:

- The electric components are "CE" marked in accordance with 89/336/CEE and 76/117/CEE european directives.
- The electric supply voltage and the electric values of the signals must be checked before connecting the components.

Never exceed the values stipulated in this leaflet

This box is an electric device. As such, it may be a source of danger for property or even personnel. Any excess of these values may cause damage.

Never open, uncouple or disassemble the AMTROBOX R when energized.

***During workshop or on-site checking, the valve associated with the actuator and its AMTROBOX R box can be operated from full open to full closed position.
This operation may be of a high significant risk of personal injury if the safety steps required are not taken to prevent access between the disc and the seat.***

Mounting on actuator

AMTROBOX R is fitted on the actuator according to VDI/VDE 3845 interface.
The four screws can be reached easily by opening the top cover.
The driving of the shaft is done by coupling on the actuator pinion.

Adjustment of open/close detection

The limit switches or detectors are factory adjusted.
It is not necessary to re-adjust before valve mounting on site.
Nevertheless, if you wish to re-adjust after a maintenance operation, proceed as follows:

- Remove the top cover of AMTROBOX R by unscrewing it with a wrench.
- Put the disc in extreme position (opening or closing).
- Unscrew the two metal screws one turn.
- Adjust triggering of the required detector by turning the coloured screw corresponding to the colour of the cam to adjust.
- Proceed in the same manner with the opposite switch.
- Each cam is adjusted independently and the adjustment does not affect in any way the adjustment of the other cam.
- When adjustments are completed, slightly tighten the two metal screws to prevent adjustments being changed.
- Replace the top cover of the box by screwing it with a wrench.

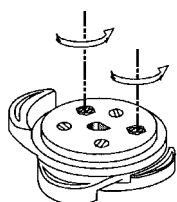

1 - Loosen the metallic screws

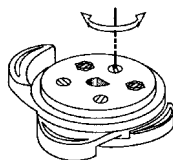

2 - Adjust the cams

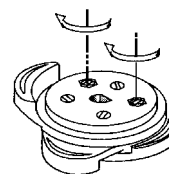

3 - Tighten the screws

Angle sensor adjustment

Following actuator position on the pipe ("N" or "M" mounting), angle sensor position must be adjusted.
Use a screwdriver to adjust the angle sensor position. See diagram below.

"N" mounting

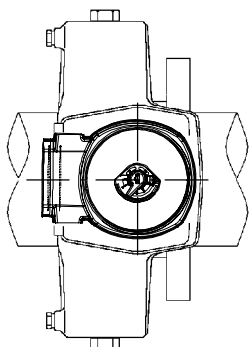

"M" mounting

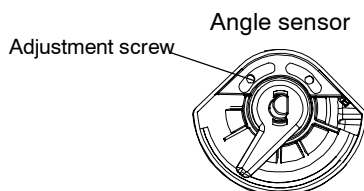
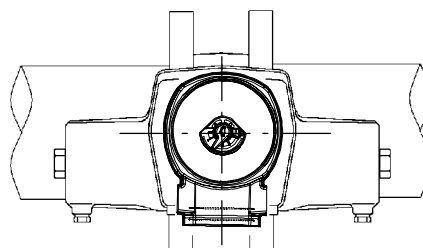

4-20 mA transmitter internal wiring diagram Box RA 1187

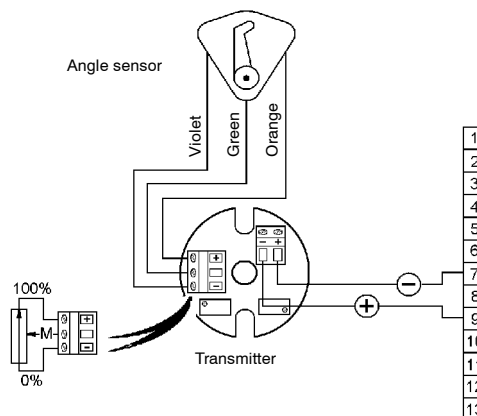

4-20 mA transmitter adjustment

When AMTROBOX R is delivered with its actuator, the transmitter is preadjusted in workshop.

It is not necessary to re-adjust it before valve mounting on site.

Nevertheless, if you wish to re-adjust it after a maintenance operation, proceed as follows:

- Remove the top cover of AMTROBOX R by unscrewing it with a wrench.
- Two adjustments are available for the zero adjustment (4 mA) and the gain (20 mA) thanks to two potentiometers.
- Replace the top cover of the box by screwing it with a wrench.

Box RA 1187

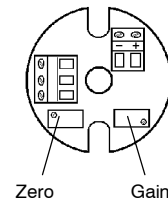

Box R 1187
All options

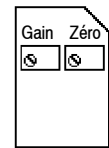

Electric connection

The box can be delivered with a plug or a packing-gland

In standard version, it is equipped with one packing-gland M20 x 1.5 or M 25 x 1.5, metallic or plastic.

Gland capacity: cable external dia. 6 to 18 mm. Other gland capacities are possible.

The wiring is done by connector, capacity 0.08 to 1.5 mm².

Open the side cover to access to the terminal block by unscrewing with a wrench.

The good tightness of the box depends on cable selection and tightening of packing-gland. See wiring diagrams (pages 7, 8 and 9).
Screw the side cover with a wrench.

Wiring diagrams

Boxes R 1187 - Microswitches or detectors

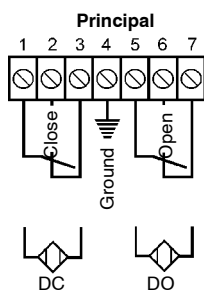

Customer connection for the detectors

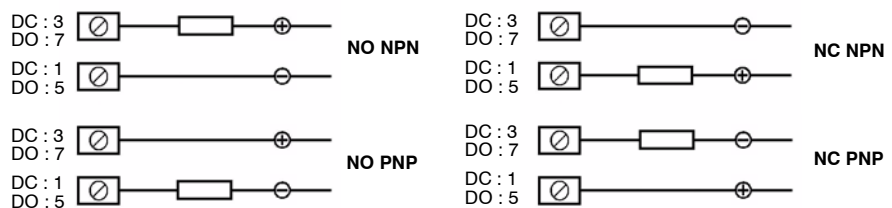

Bus

Boxes R 1187 - All options

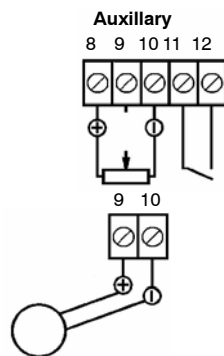
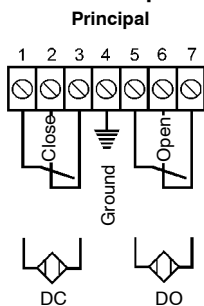

Profibus DP

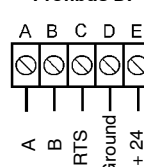

AS-i

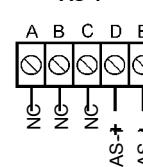

Boxes RA 1187

1/O and 1/F

2/O and 2/F

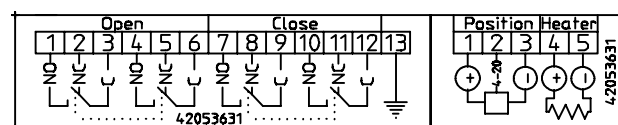
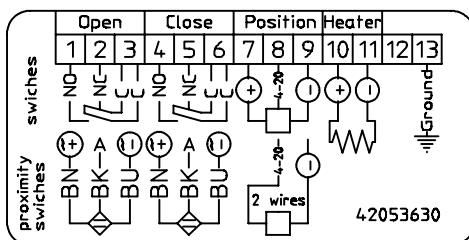

Assembly fitting instructions for installation of cable gland type T3CDS

Always adopt safe working practices as your prime consideration, and use good engineering principles when carrying out your duties. Everyone is responsible for following corporate health and safety requirements.

These Cable Glands are certified EEx d IIC & EEx e II as Category 2 IIGD equipment for use in Zone 1, Zone 21, Zone 2 and Zone 22 Hazardous Areas with Braided, SWA (Single Wire Armour), Strip Armour, and Tape Armour cables, providing a flameproof seal on the cable inner sheath, and an environmental seal to the cable outer sheath with the added benefit of deluge protection to the armour lock chamber.

Please read these instructions carefully before beginning the installation.

This cable gland design has four key elements to its general construction, as shown by the diagram below. When opening the cable gland there are two loose components, the armour cone and clamping ring, which facilitate a disconnectable arrangement.

It is not necessary to dismantle the cable gland any further than illustrated below.



Installation instructions

1. Select the correct cable gland size using physical dimensions of the cable cross-referenced against the selection table opposite.
2. Separate the cable gland into two sub-assemblies A and B.
Note : Items 4 and 5 are loose components (See diagram above).
3. Determine conductor length required and strip back cable outer sheath and cable braid or armour to suit the equipment geometry. (Note, when cutting armour wires, care should be taken to avoid cutting into the inner cable sheath beneath the armour wires). Expose the cable braid or armour further by stripping the outer sheath enough to allow contact with the tapered cone. This length may vary slightly depending upon diameter of the cable. See fig 2 and table opposite for guidance.
Note :The reversible armour cone is suitable for terminating several cable armour types including Braid, SWA (Single Wire Armour), Strip Armour and Tape Armour. Identification of the cable armour types is marked on the cone.
For reference :
Smooth / Plain Side of Cone is for terminating SWA Cable (W)
Grooved Side of Cone is for terminating Braid, Strip Armour or Tape Armour (X, Y, Z)
4. Secure entry component (sub-assembly A) into equipment using a spanner, and in cases where a locknut is to be fitted inside the equipment, two spanners will be required to tighten correctly.
5. Pass sub-assembly B and clamping ring ⑤ over the cable, outer seal nut first.
6. Insert reversible armour cone ④, in the orientation to suit the cable braid or armour type, into compensating sleeve ③ and pass the cable through sub-assembly A equally spacing the braid or armour around the cone. See fig 3.
7. Whilst continuing to push the cable forward to maintain the cable braid or armour in contact with the cone, tighten compensating sleeve ③ into entry component ① until the components are metal to metal, and cannot be tightened any further.
8. Terminate the cable braid or armour by first securing entry component with a spanner (to prevent additional stress being transferred to entry threads) then tighten body ② onto entry component ① using a second spanner until the components are metal to metal, and cannot be tightened any further.
9. Close outer seal by tightening outer seal nut ⑥ onto body ②. Figure 5 shows a completed assembly.

Remote installation

1. For remote installation follow steps 1 to 9 opposite, ignoring step 4.
2. Disconnect body ② from entry component ①. Unscrew compensating sleeve ③ until cable can be withdrawn from entry component.
3. Remove the actually cable by a new cable (See step 3, previous page).
4. Follow the steps 4 to 9 (See previous page).

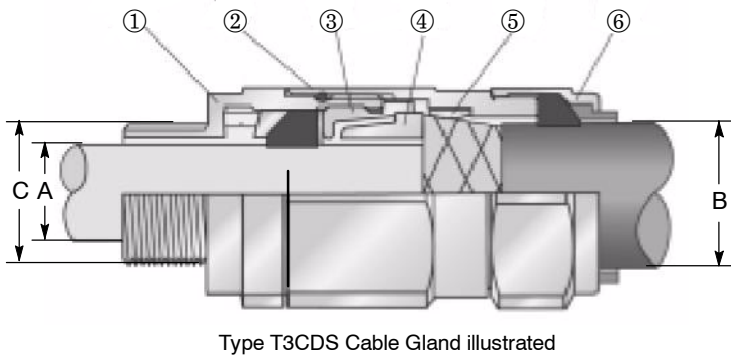
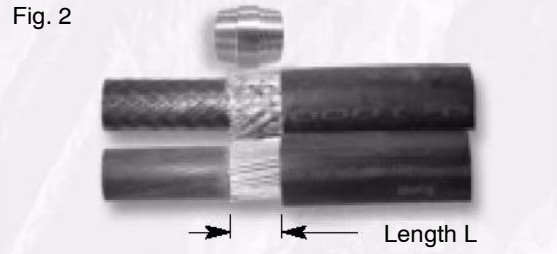

| Gland Size | Entry Threads C | Min. Thread | Cable Dia A | | Cable Dia B | | Cable gland size |
|------------|-----------------|-------------|-------------|-------|-------------|------|------------------|
| | Standard Metric | Length D | Min. | Maxi. | Min. | Max. | Length L |
| 20/16 | M20 | 15 | 3.1 | 8.6 | 6 | 13.4 | 12 |

Product features - to our Customers' Benefit

**AMTROBOX R
Robust design for harsh applications**

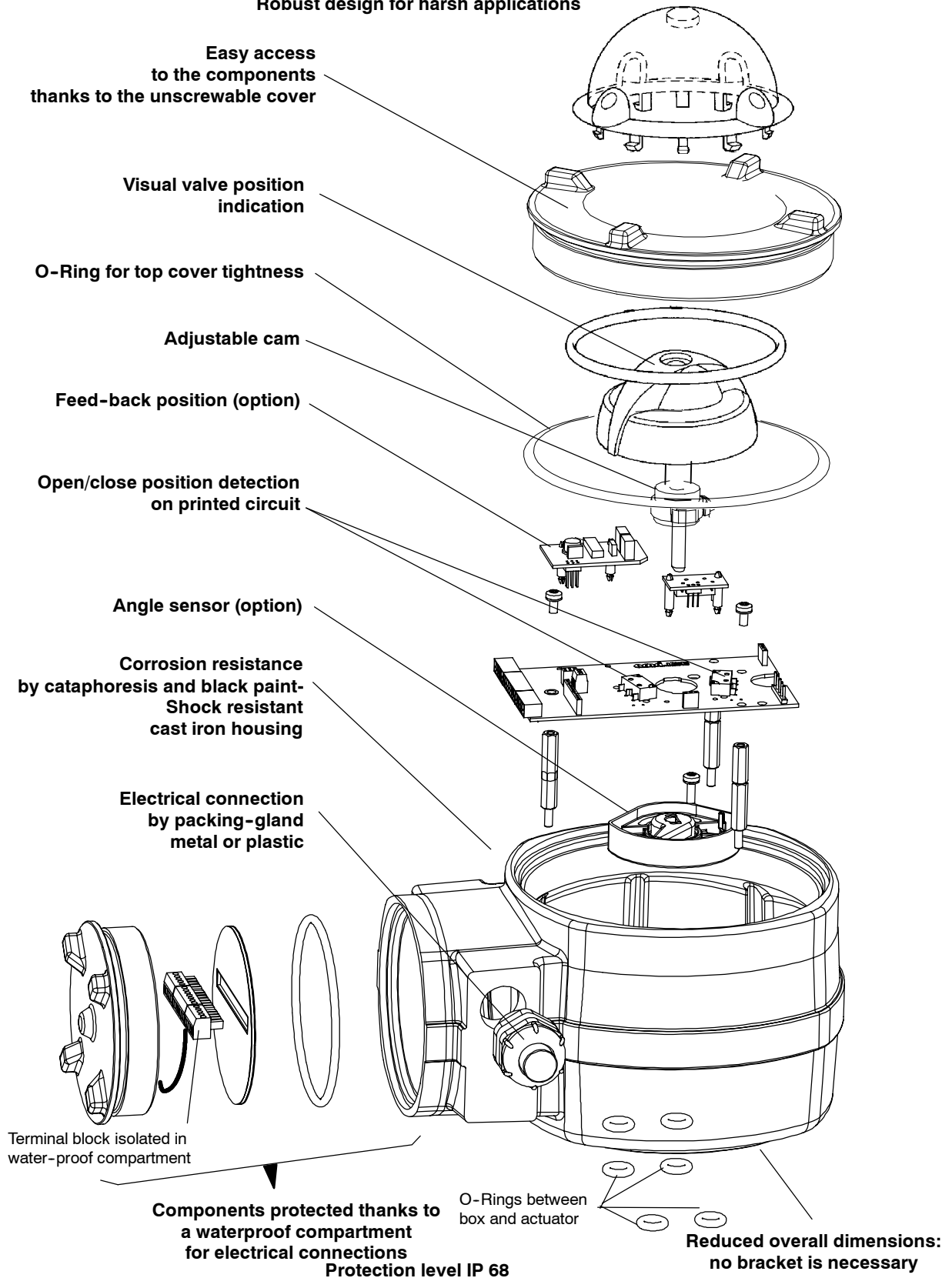

This leaflet is not contractual and may be amended without notice.

22.07.09

8525.11/8-10